



Commanding Mission Groups – a model for Transitional NEC.

Lt Col Merfyn Lloyd OBE

9th ICCRTS, Copenhagen
14 - 16 September 2004



Use Cases



30 September, 2004

© Dstl 2004



Dstl is part of the
Ministry of Defence

Analysis



- Operational View

- How business is done for real, capturing the process.
- Must be causal not time based.

From Use Case

- Organisational Relationships

- Relationship of entities in military command decision making terms.

- Operational Activity Model

- Relationship of entities in time and space.

From Capability Chain

- Information View

- How information is shared.
- The ability of entities to share information. Capture logical flows.

From a combination

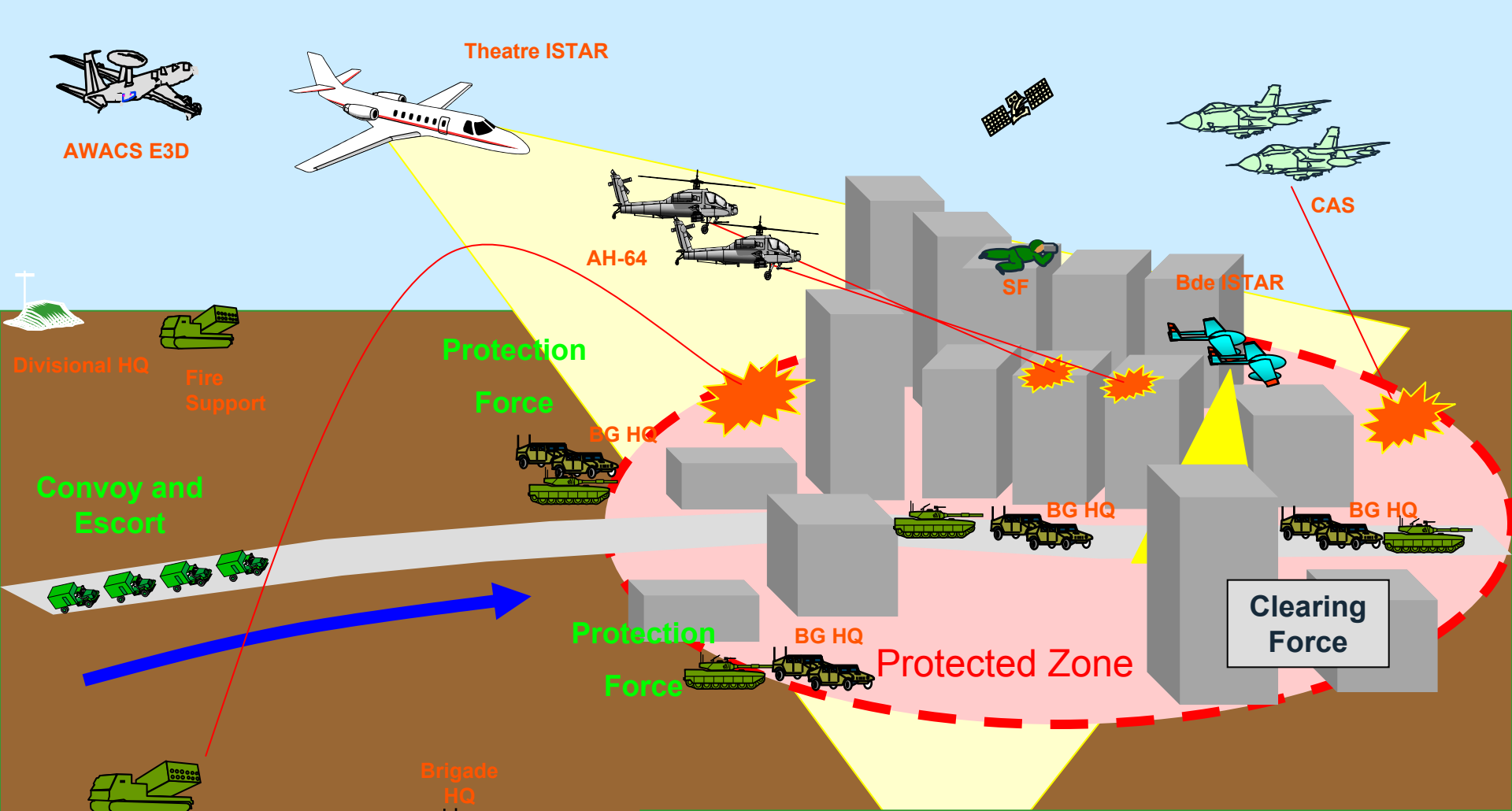

Operational View (OV 1)

Urban Operations - Clearing MSR

Military Metrics



Military Success Criteria	Components	Elements
Military MOE: Ability for convoys to transit MSR at any time without loss	Size of force needed for clearance /size of force needed to maintain MSR open.	Ability to command and control the force in complex urban terrain.
		Effectiveness and coverage of Urban ISTAR in providing accurate useable information.
		Ability to identify and discriminate BWR forces /individuals in 3-D built up terrain in and out of buildings.
		Accuracy and availability of GIS (Ability to know precise location of BWR (1m in 3-D /5 sec)).
	Speed of clearance.	Level of SA /C2.
		Accuracy and coverage of BWR picture.
		Accuracy and availability of GIS.
Parameters: Timeliness Size of force needed to hold effectively	No of BWR casualties.	Level and quality of SA /C2.
	Avoidance of PR disaster areas.	
	Avoidance of Collateral damage.	Level and quality of SA /C2.
	Avoidance of PR disaster areas.	
Ability to detect and neutralise SMERCH rockets in 10 minutes.	Detect SMERCH.	
Neutralize SMERCH in 10 minutes.		

Information View (OV 2)



From Left to Right	JTFC	JFLCC	JFACC	JFSFCC	Div	Bde	BG	UCT	Convoy	Th ISTAR	UAV	E3D	AH 64
JTFC		Direction, SA	Direction, SA	Direction, SA									
JFLCC	Status, SA		Status, SA, Requests for tasks and information	Status, SA, Requests for tasks and information	Direction, SA	Awareness							
JFACC	Status, SA	Status, SA, Requests for tasks and information		Status, SA, Requests for tasks and information	Status, SA	Status, SA				Coord	Awareness	Direction, SA	Coord
JFSFCC	Status, SA	Status, SA, Requests for tasks and information	Status, SA, Requests for tasks and information		Coord							Awareness	
Div		Status, SA	Status, SA	Status, SA		Direction, SA	Awareness	Awareness	Awareness	Direction, SA	Awareness	Awareness	Direction, SA
Bde					Status, SA		Direction, SA	Awareness	Direction, SA	Awareness	Direction, SA		Coord
BG						Status, SA		Direction, SA	Coord		Awareness		Coord
UCT							Status, SA		Coord	Coord	Coord		Coord
Convoy							Status, SA	Coord	Coord		Awareness		
Th ISTAR			Status, SA		Awareness	Awareness		Coord			Awareness	Coord	Coord
UAV						Awareness	Awareness	Coord	Awareness	Awareness		Awareness	Coord
E3D			Status, SA		Awareness	Awareness				Coord	Awareness		Coord
AH 64			Status, SA		Awareness	Awareness	Coord	Coord		Coord	Coord	Coord	
CAS			Status, SA				Coord	Coord	Coord		Coord	Coord	Coord
Fire Sp		Status, SA			Coord	Coord	Coord	Coord	Coord	Coord	Awareness	Coord	Awareness
SF				Status, SA	Awareness	Awareness	Awareness	Coord			Awareness	Coord	Coord

Chain 1

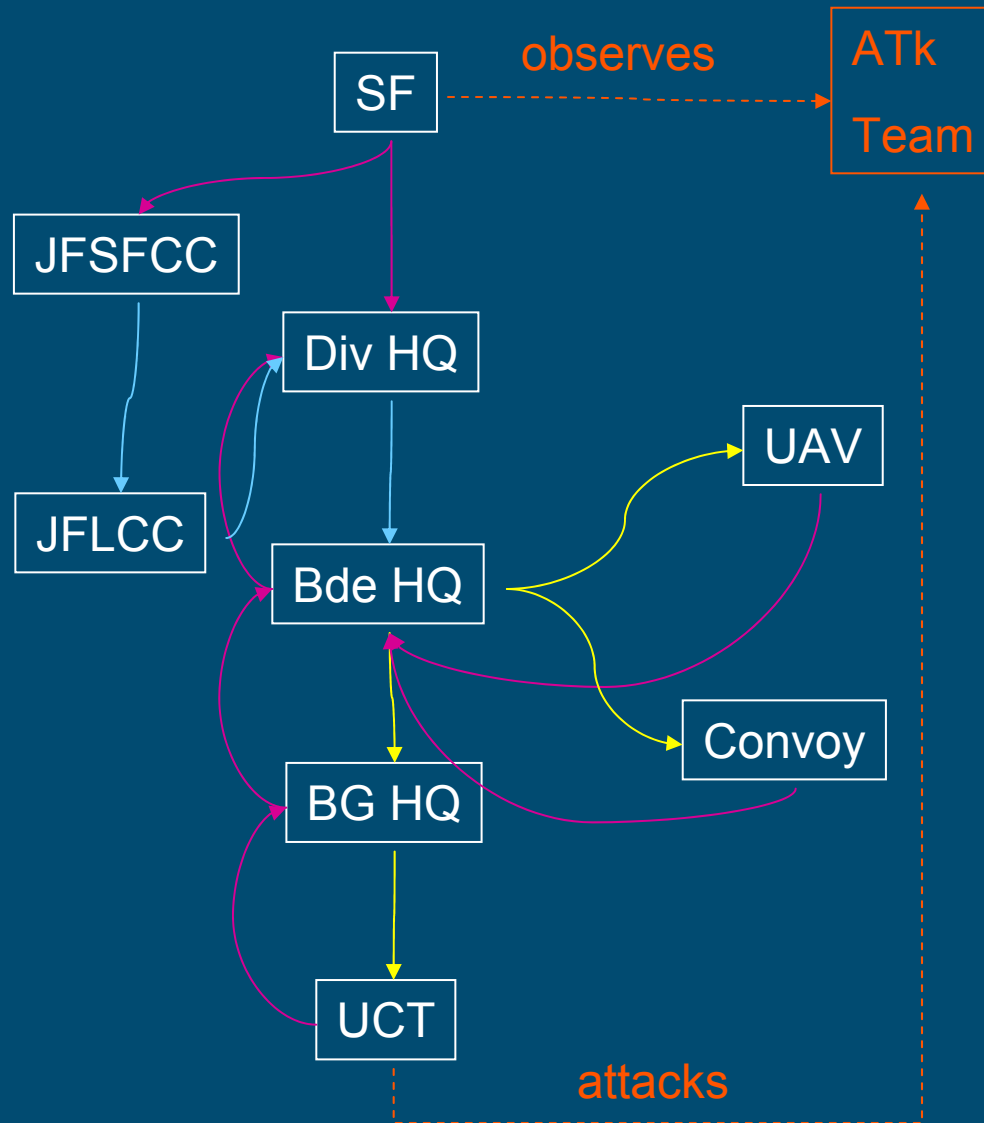

Lessons from Use cases



- Not everyone needs to talk to everyone else.
- People work in communities.
- Agility at the tactical level depends more on peer-to-peer relationships than hierarchical command structures.
- Universalist v Communities view.

Operational Infrastructure



30 September, 2004

© Dstl 2004



Dstl is part of the
Ministry of Defence

Architectures

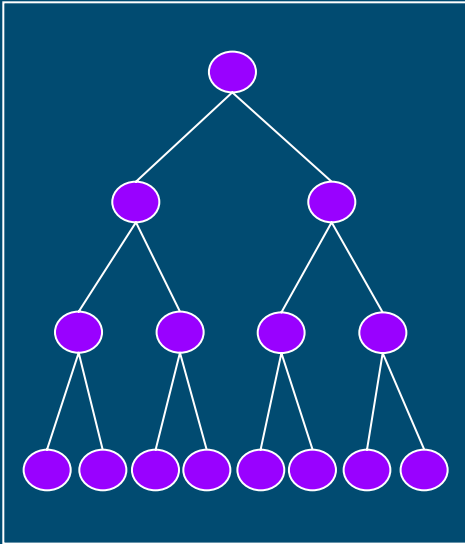

Current hierarchical
architecture -
Initial
NEC State

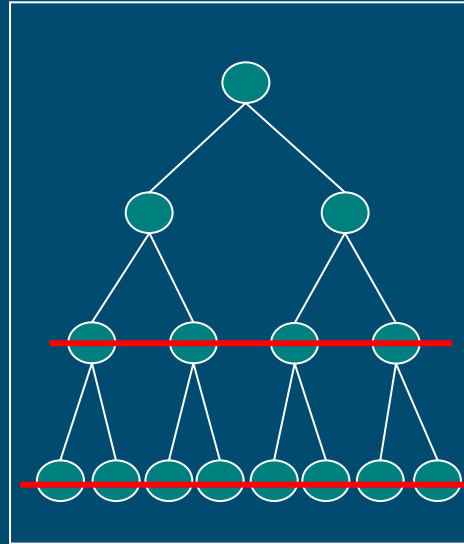

Proposed 2015
architecture -
Transitional
NEC State

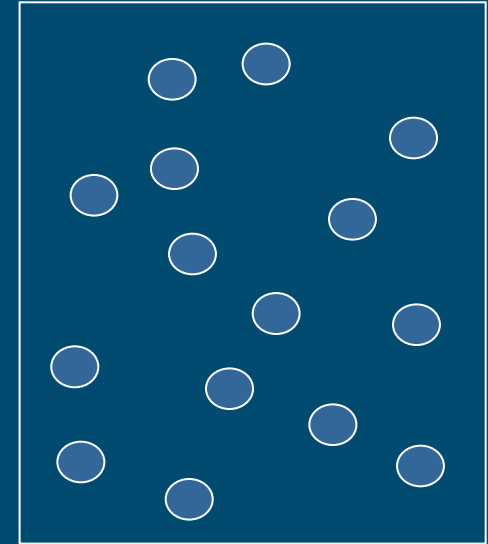

Self-synchronising
architecture -
Mature
NEC State ?

Actions and Operational Groups

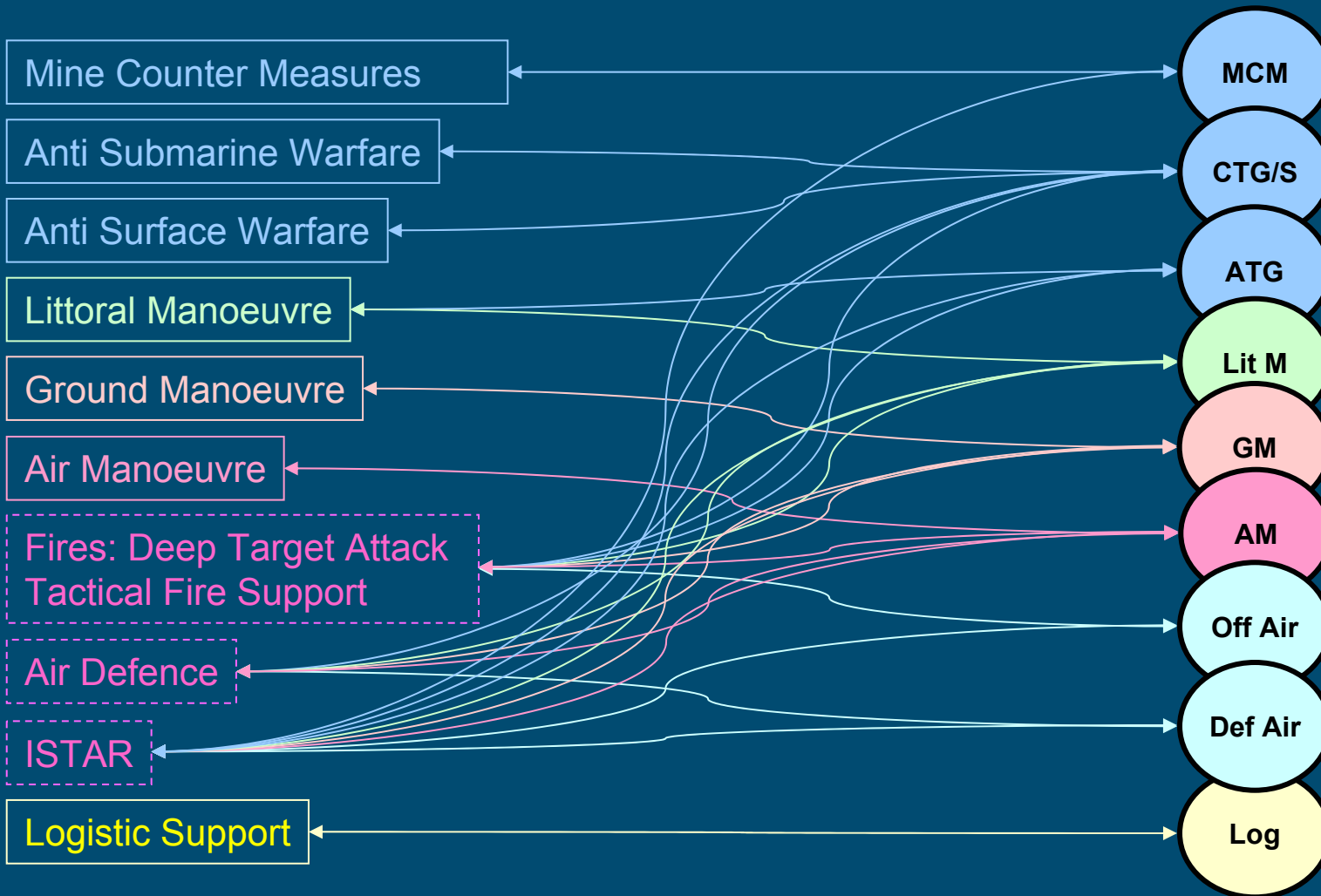

Command

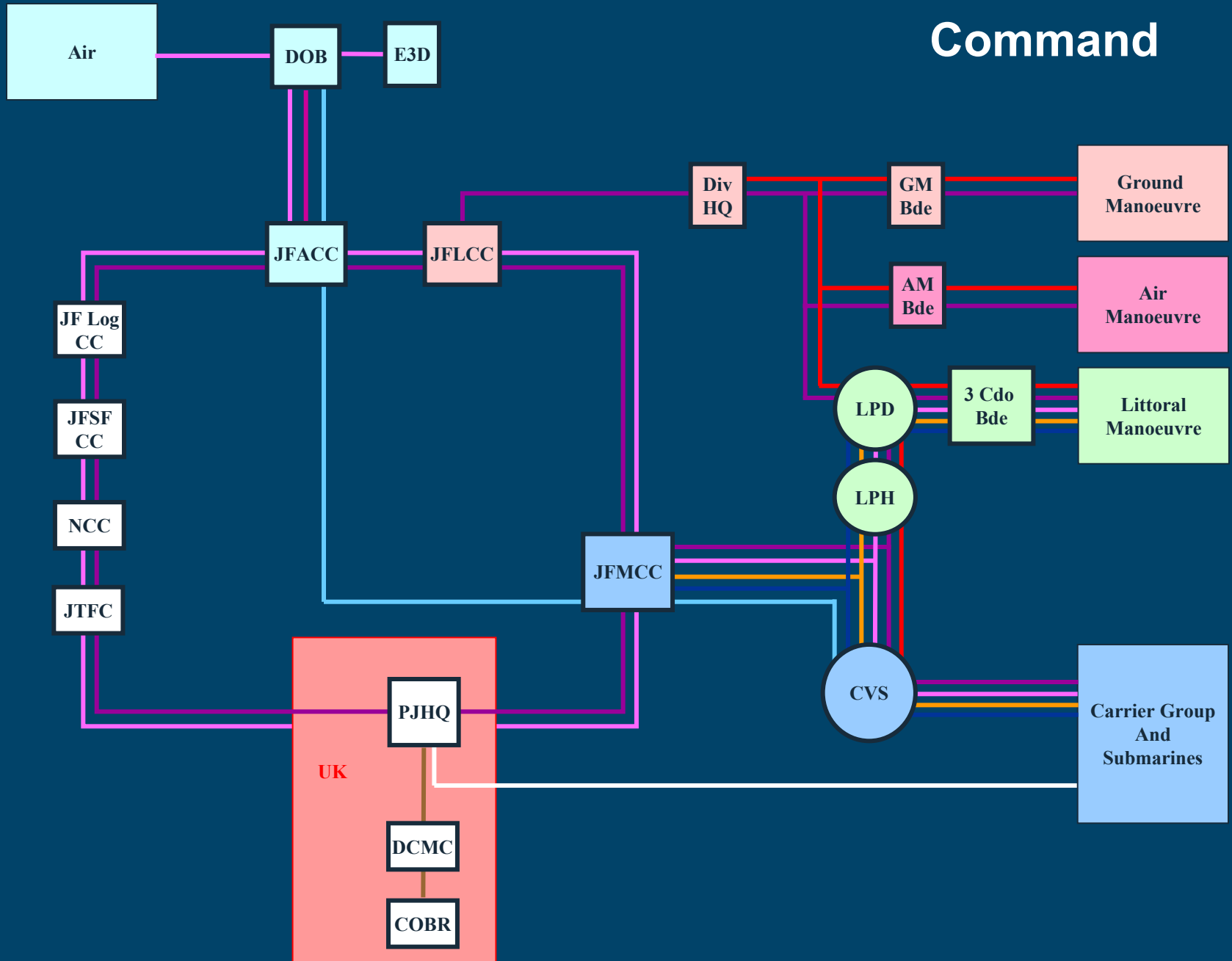

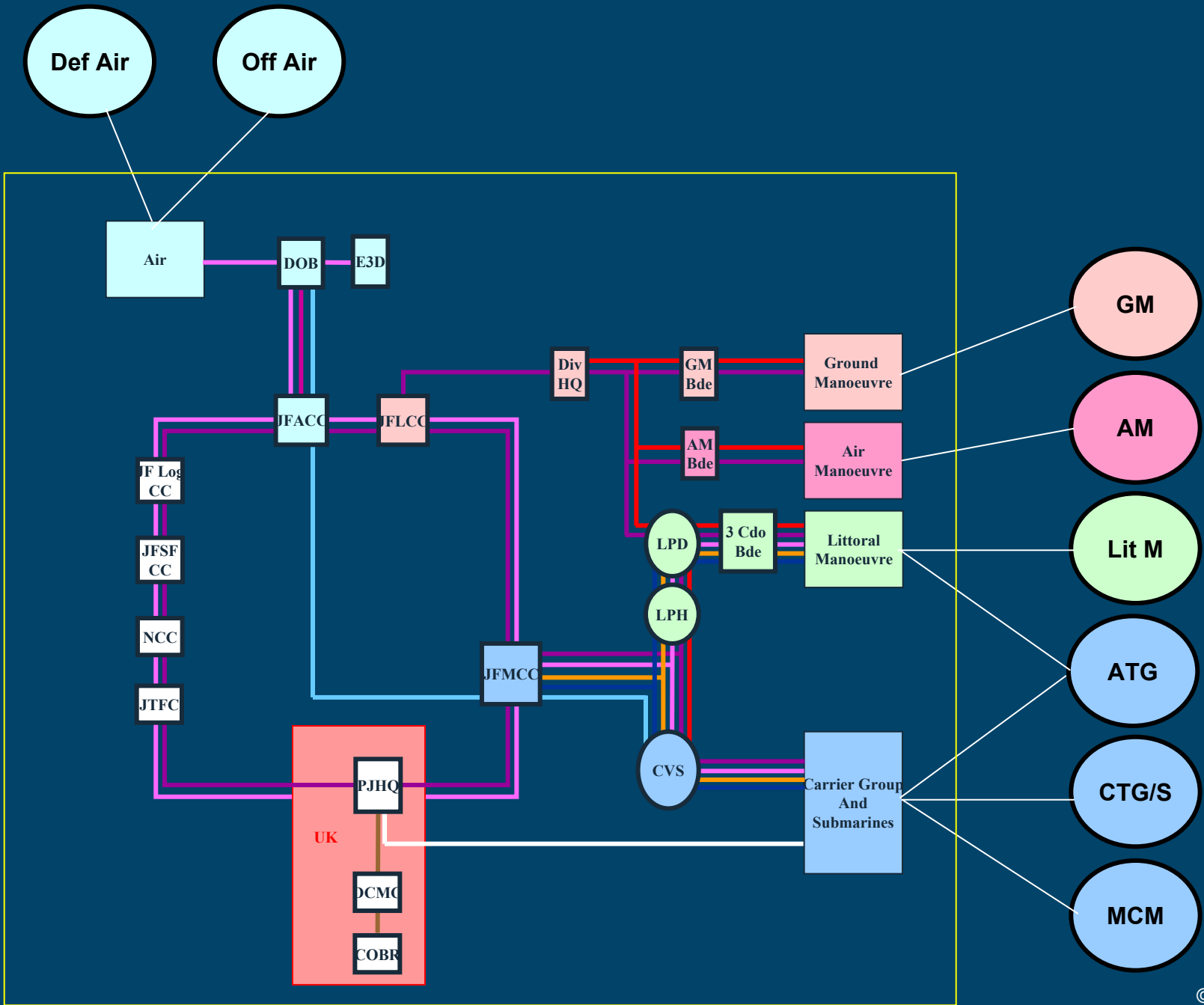



Planning: Deployed Command

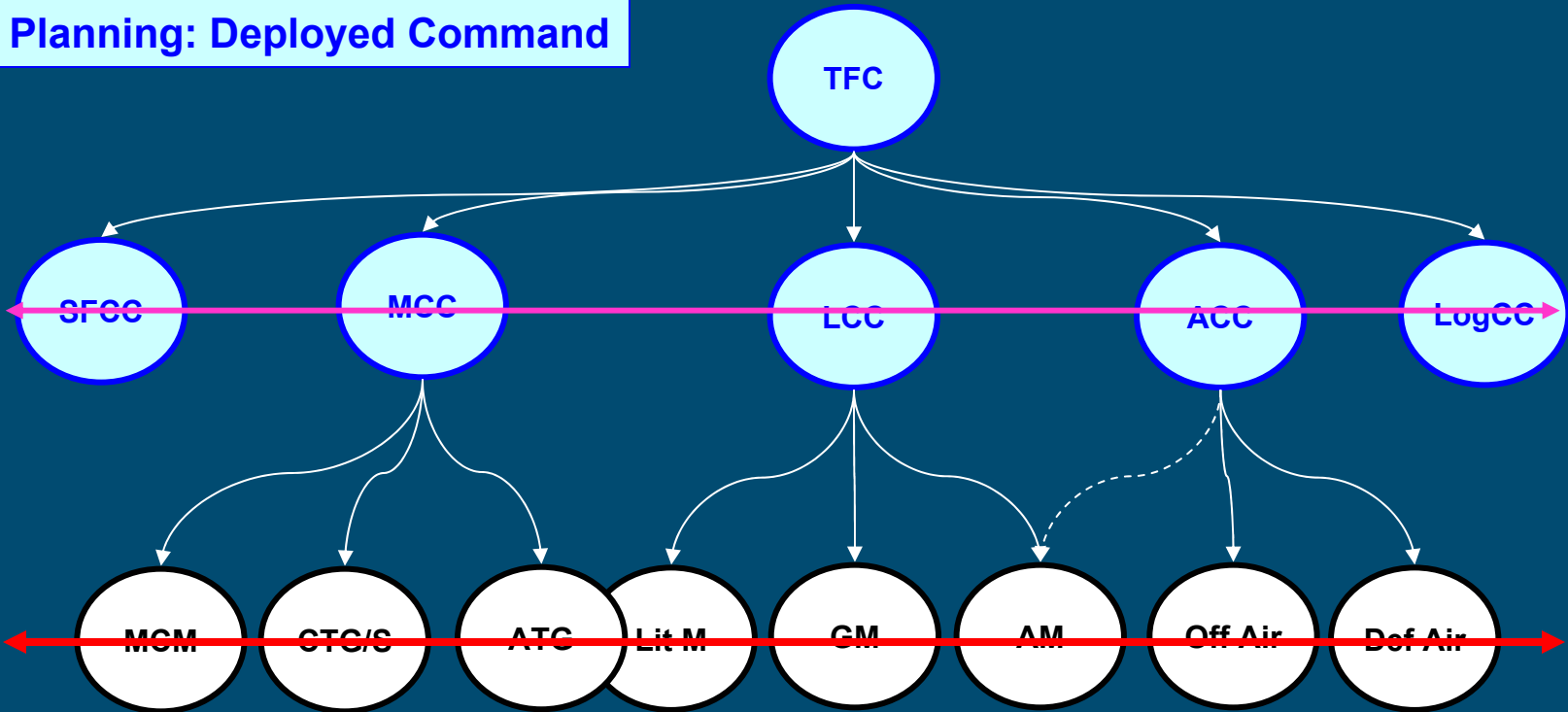

Execution: Deployed Operational Groups



Command /Planning

Planning: Deployed Command

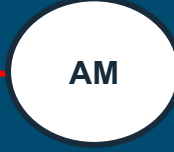
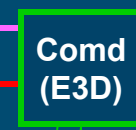
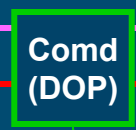
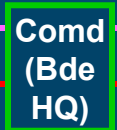
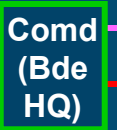
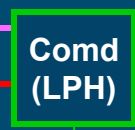
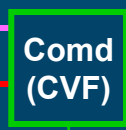
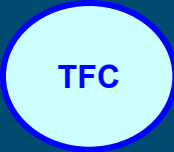

Execution: Deployed Operational Groups

DOG Key Node

Responsive Support Components

Commonality across DOGs

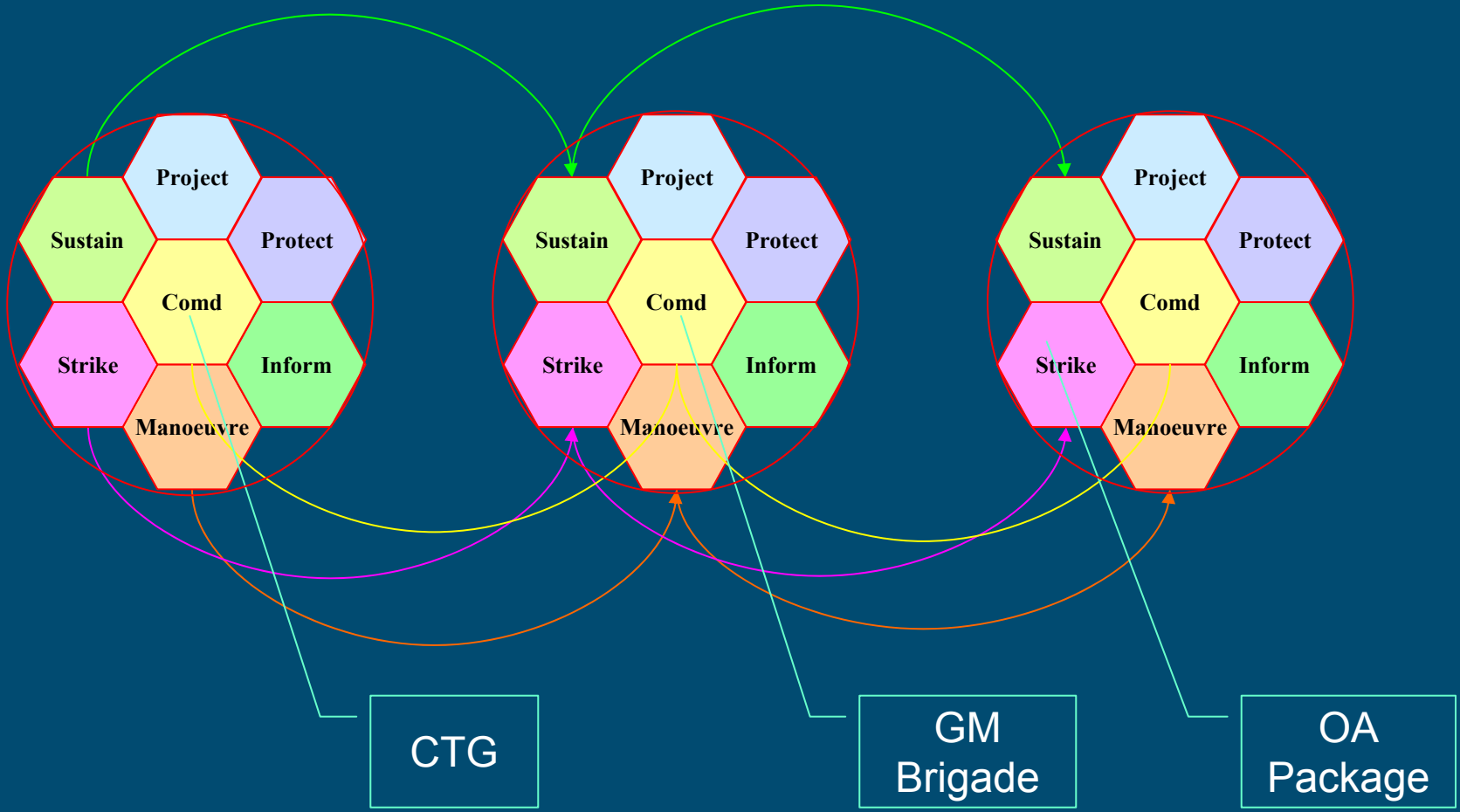

30 September, 2004
© Dstl 2004



Dstl is
Minis



Ground Manoeuvre (Medium) 2015

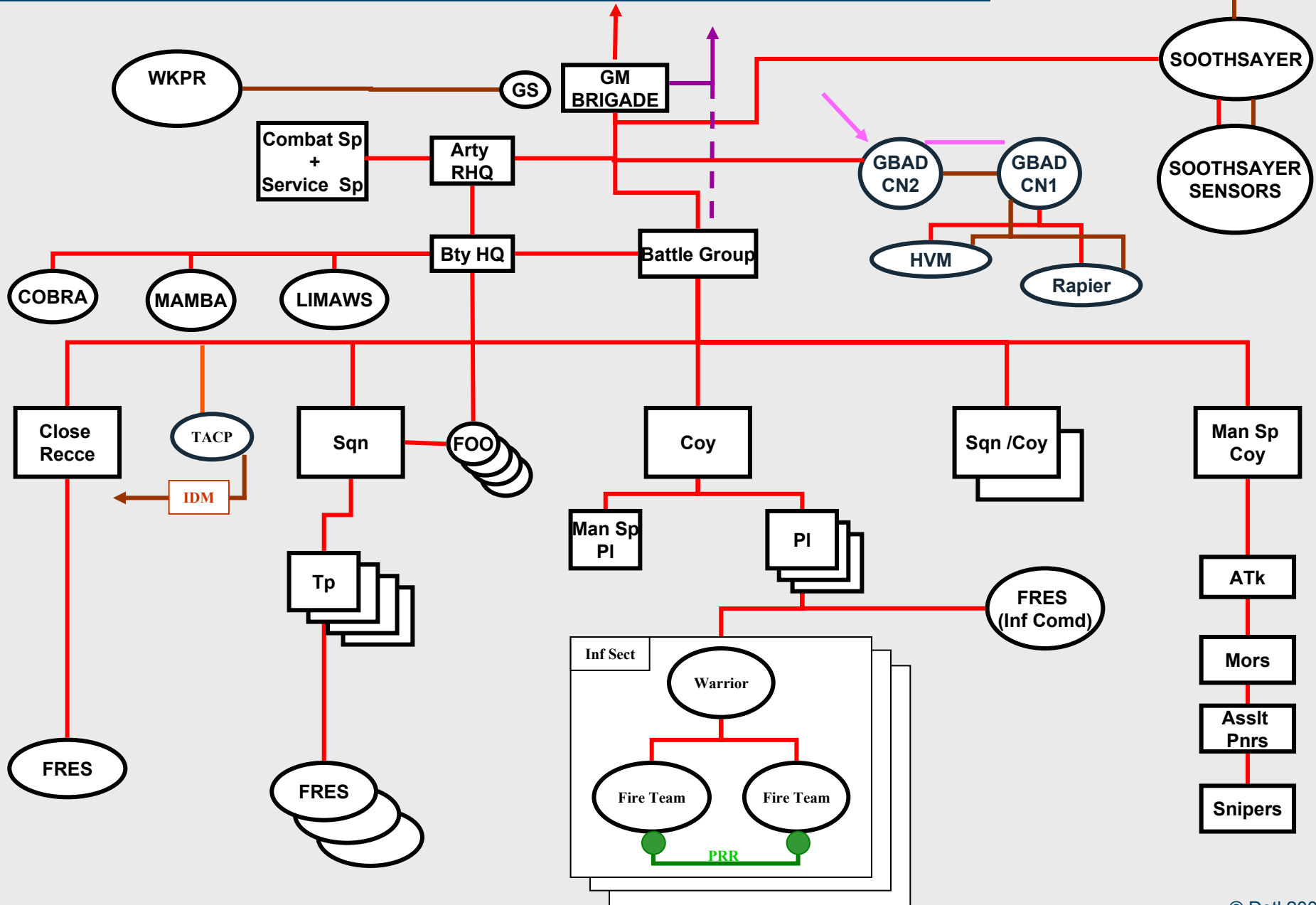

Ground Manoeuvre (Medium) 2015

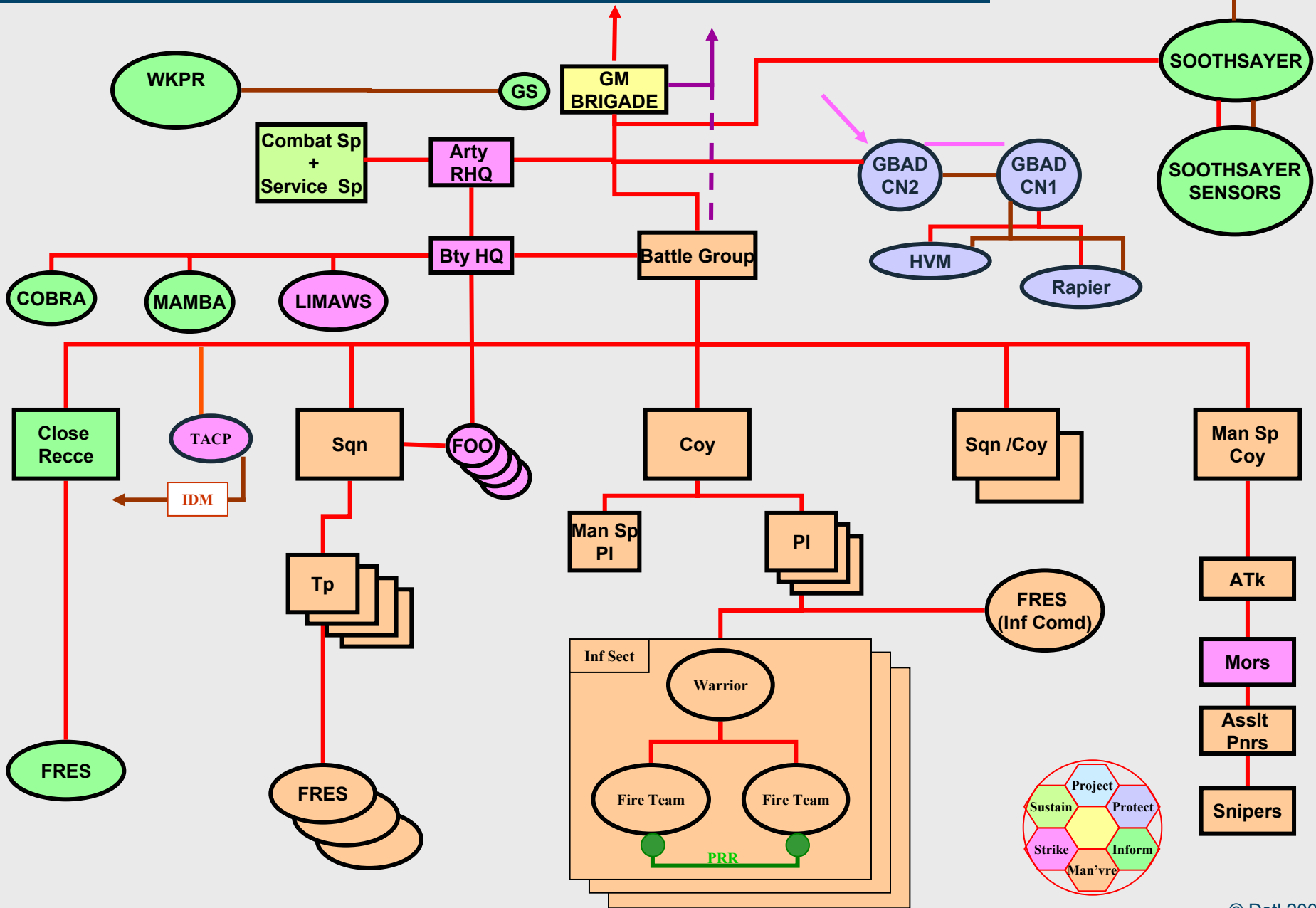

Capability Architecture 2015

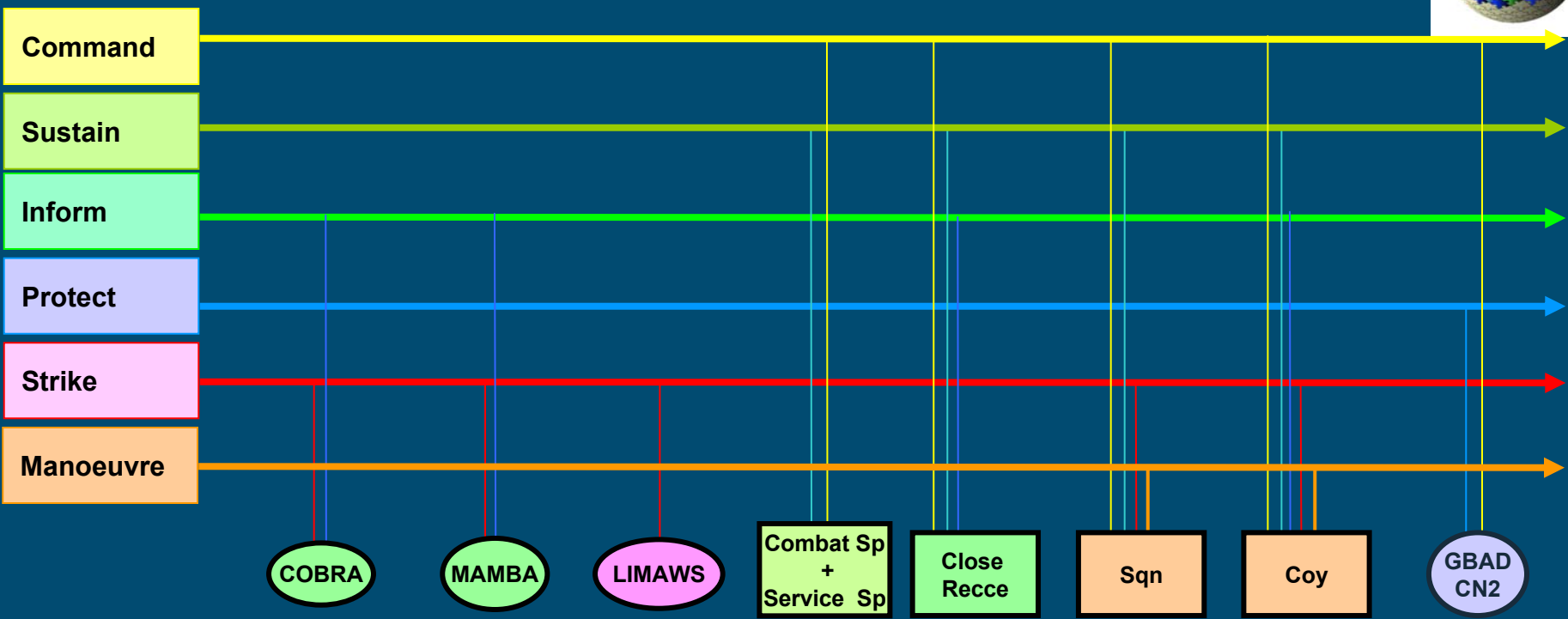

Capability Architecture 2015

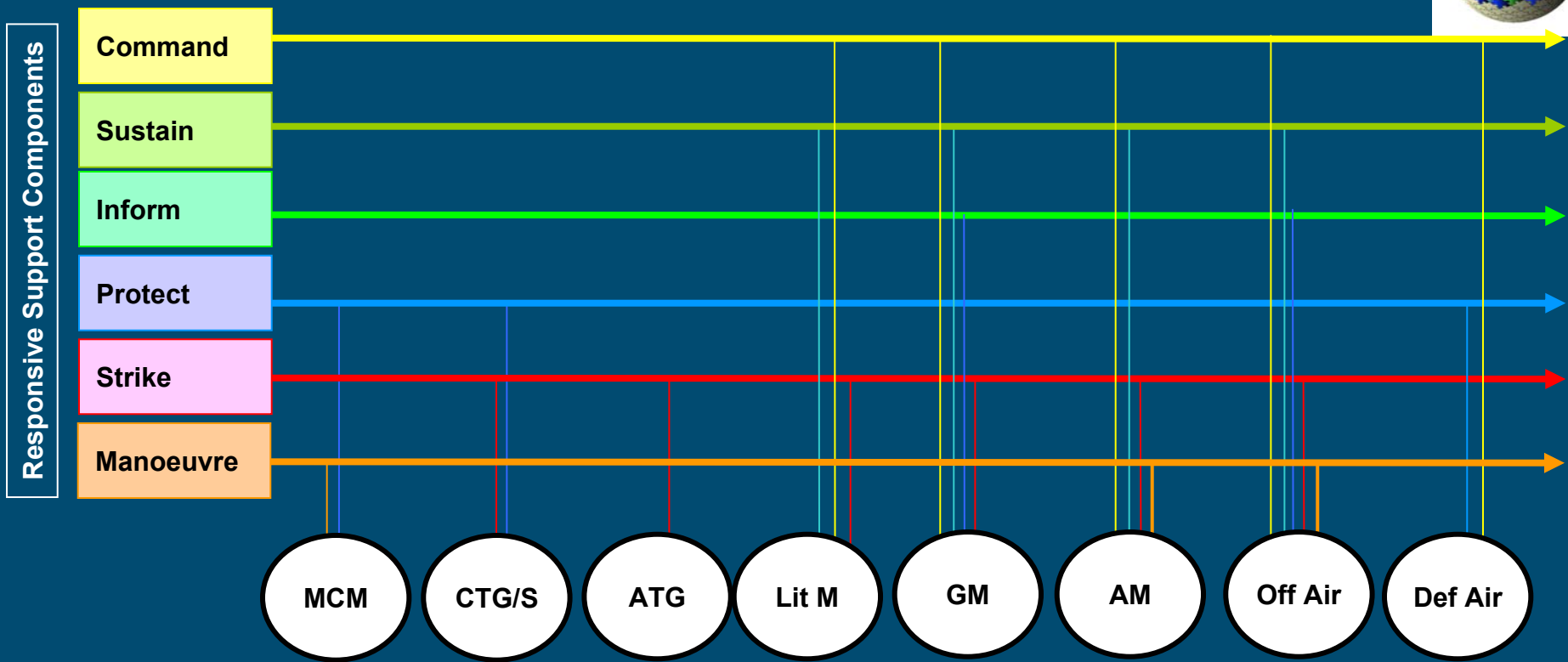

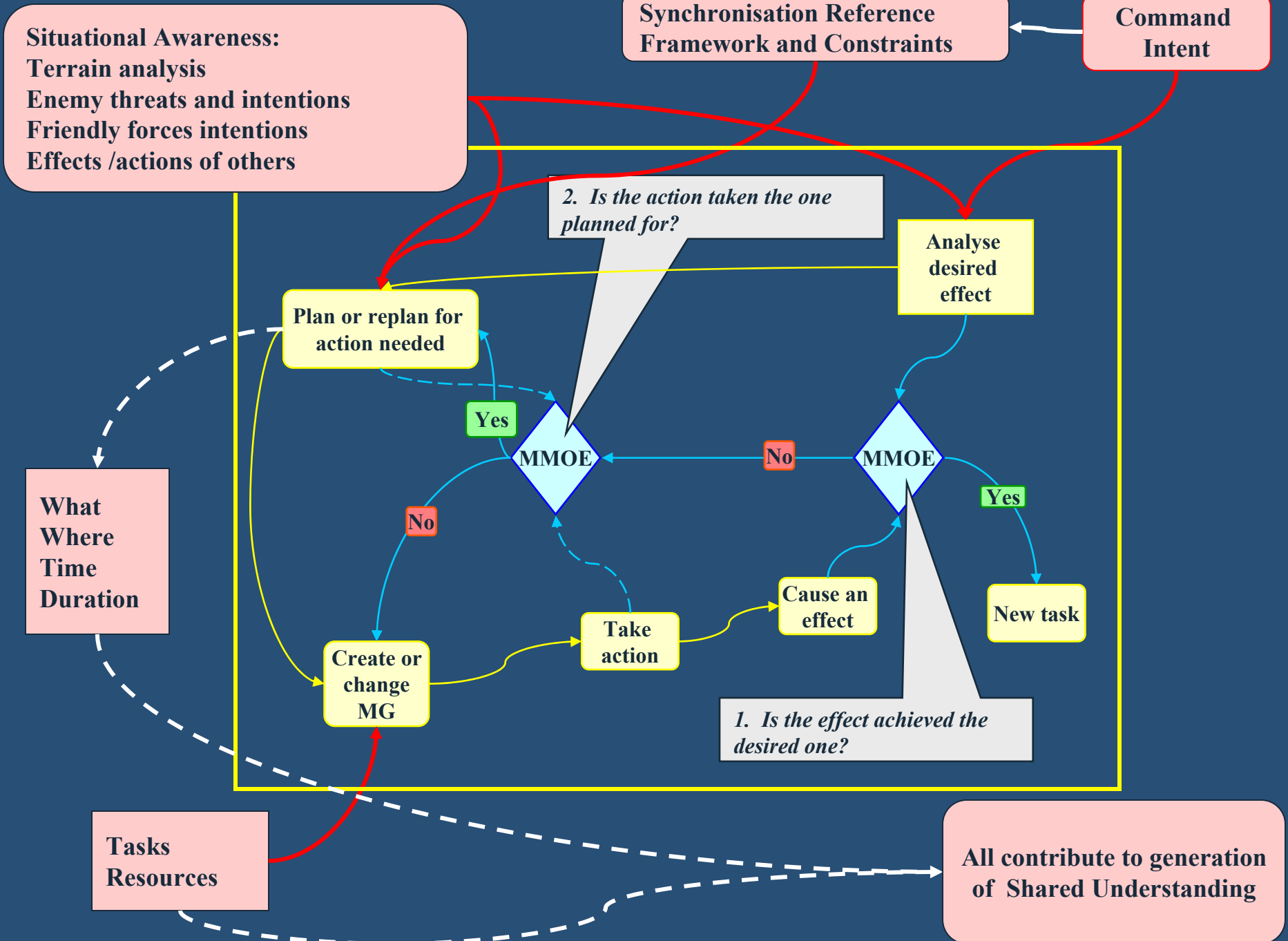

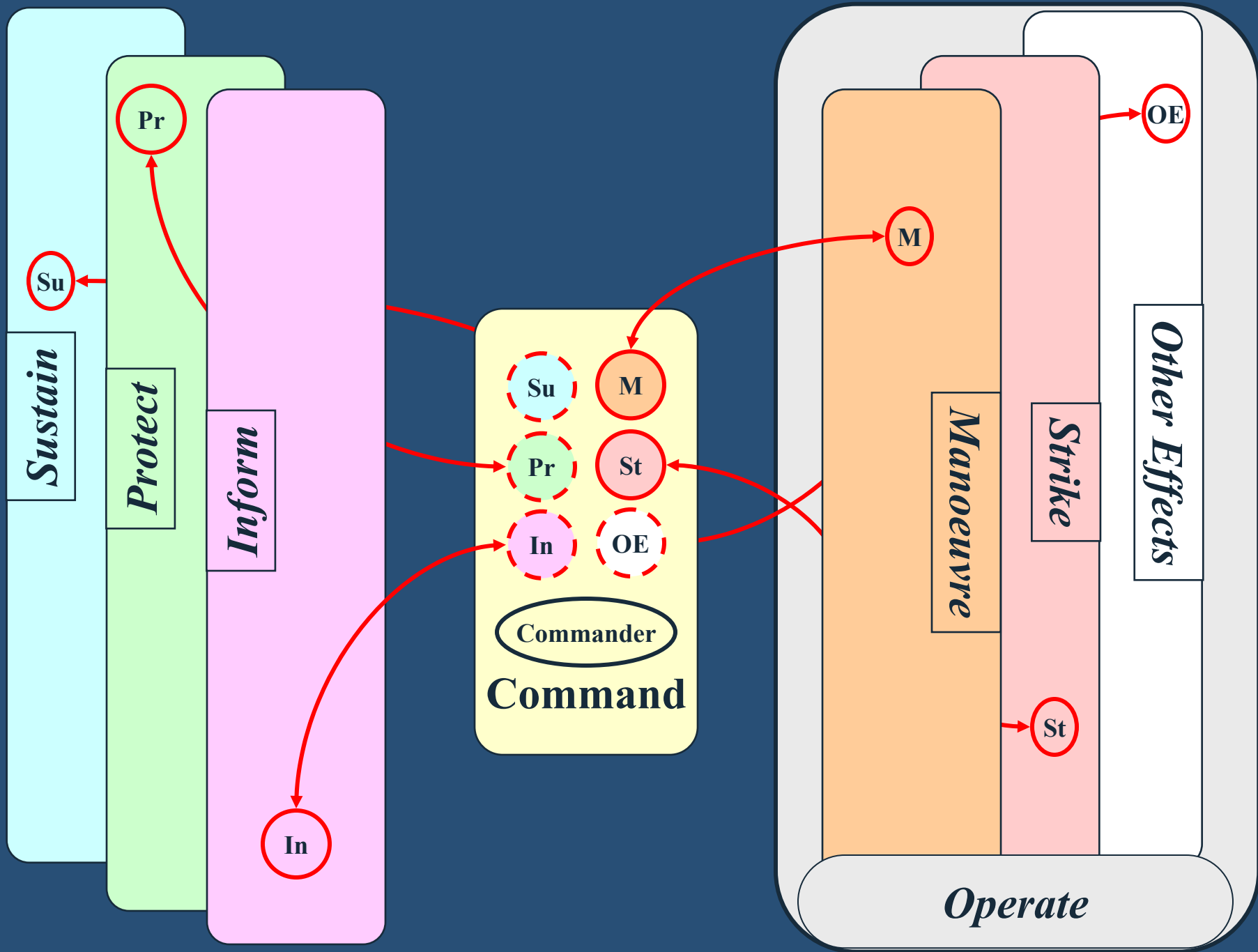

Transitional 2015



- A communities view of working:
 - Not universalist.
 - Basis are deployed operational groups.
- Ability to interwork at various levels:
 - Mission groups formed through membership or participation.
- Based on the provision of functional ‘managed’ services
 - Greater freedom given by higher commanders
 - Control exercised through management of services
 - Importance of Command Intent as the ‘synchronising mechanism’.



Lt Col Merfyn Lloyd

SO1 CBM

DSTL

St Andrews Road

MALVERN

WR14 3PS

United Kingdom

+44 (0)1684 77 1472

Malloyd@dstl.gov.uk