

# **MULTI-SENSOR INFORMATION FUSION TECHNOLOGY APPLIED TO THE DEVELOPMENT OF SMART AIRCRAFT**

By

**Dr. Buddy H. Jeun and Honorary Professor Allan Whittaker, Senior IEEE  
Lockheed Martin Aeronautics Company  
Marietta, Georgia**

## **ABSTRACT**

This paper explores the possibility of applying multi-sensor information fusion technology to the development of smart aircraft. This technology integrates information from multiple sensors and extracts tactical information to detect, track and identify time critical targets at any time, in any place and under all weather conditions. Such target information will help the war fighter avoid fratricide and deploy weapon systems for surgical strike. Finally, the smart aircraft helps the war fighter establish air superiority in the air, on the land and at sea.

The architecture of a smart aircraft includes the pilot and flight crew, vehicle interface unit, multi-sensor correlation processor, multi-sensor image fusion model, multi-sensor track fusion model, multiple target identification fusion model and multiple sensors such as: Radar, CNI, EW, IFF Visual, Electro Optic and IR.

The multi-sensor track fusion model computes a fused track from the sensor trackers. A Multiple Target Identification Fusion model creates integrated target identifications from identification of multiple targets. Similarly, a Multi-Sensor Image Fusion model creates an integrated target image from multiple sensor images.

In traditional aircraft, the pilot and crew extract tactical information from a huge amount of multi-sensor information. This processing is time consuming and subject to human error. A future smart aircraft with Multi-Sensor Information Fusion technology will have access to accurately correlated fused information. Fused information assists the pilot and crew to detect, track and identify targets more rapidly and accurately. Such platforms are truly smart aircraft.

## 1 INTRODUCTION

The smartness of the fighter aircraft can be characterized by the following qualities:

- (1) Quickly assess the tactical information from the multi-sensor and multiple target environments.
- (2) Positively detect, track, and identified the time critical targets at any time and any place under all weather conditions.
- (3) Accurately deploy weapon system for surgical strike to the enemy target.
- (4) Precisely discriminate targets from friends and foes, to avoid friendly killing.

Most aircraft development involves multiple sensors. Some sensors such as synthetic aperture radar can provide picture like images at very long range. Sensors, such as radar, IFF, electro-optic cameras and infrared images, can provide tactical information to detect, track and positively identify targets. All of sensor needed to integrated in order to generate the tactical information for the smart aircraft. Integration of multiple sensors is not a simple task, as it requires the application of mathematical concepts and computer algorithms. These form the bases of multi-sensor information fusion technology, which directly influences the development of smart aircraft.

Multi-Sensor Information Fusion (MSIF) technology includes a Multi-Sensor Track Fusion (MSTF) model, a Multiple Target Identification (MTIDF) model and a Multi-Sensor Image Fusion (MSIF) model. The MSTF model creates fused tracks from the multi-sensor trackers. The MTIDF model creates fused target identifications from the multi-sensor and multiple target identification system. The MSIF model creates the fused image from the multi-sensor image information system.

Multi-sensor fusion technology is the tool to achieved multi-sensor integration. Aircraft without multi-sensor fusion information technology operates less effectively on the battlefield. Aircraft with multi-sensor information fusion technology can detect, track and identified the time critical targets quickly with great precision. Smart aircraft with multi-sensor information fusion technology can help the war fighter to avoid fratricide and help the aircrew to established superiority in the air, land and sea.

## 2 MULTI-SENSOR CORRELATION (MSC) PROCESSOR

The objective of the Multi-Sensor Correlation (MSC) processor is to provide the logic and algorithms for the fusion processor. The MSC processor estimates the linear relationship between two given feature vectors X and Y, according to the correlation coefficient between X and Y. The equation to calculate the correlation coefficient between two feature vectors X and Y, can be expressed as following:

Let:  $X = \{x_1, x_2, x_3, \dots, x_n\}$  be the feature vector of an object  
 $Y = \{y_1, y_2, y_3, \dots, y_n\}$  be the feature vector of another object  
 Then: the correlation coefficient between the two feature vectors X and Y is:

$$C_{xy} = X \bullet Y / (X \bullet X - X \bullet Y + Y \bullet Y) \quad (1) \text{ [Jeun, 1997]}$$

Where:  $C_{xy}$  is the correlation coefficient between feature vectors X and Y  
 $X \bullet X$  is the dot product of X  
 $X \bullet Y$  is the dot product of X and Y  
 $Y \bullet Y$  is the dot product of Y

Decision rules concerning the correlation coefficient might include the following:

- (1) If the Coefficient of Correlation ( $C_{xy}$ ) satisfies the following condition:  $0.95 \leq C_{xy} \leq 1.0$ , then X and Y are most likely correlated
- (2) If the Coefficient of correlation ( $C_{xy}$ ) satisfies the following condition:  $0.0 \leq C_{xy} < 0.95$ , then X and Y are most likely uncorrelated.

The boundary condition, 0.95, is selected based upon the feature vector elements' precision.

## 3 MULTI-SENSOR TRACK FUSION (MSTF) MODEL

The objective of the Multi-Sensor Track Fusion (MSTF) model is to create the fused track from the multi-sensor trackers. Figure 1 depicts a Multi-Sensor Track Fusion model block diagram.

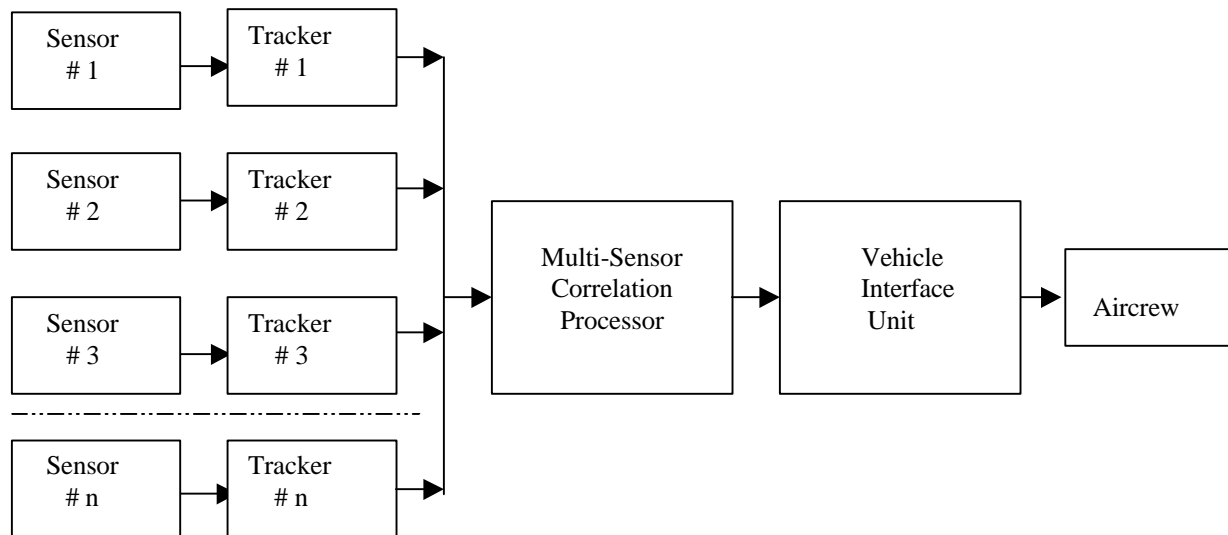

Figure 1: The Multiple-Sensor Track Fusion Model block diagram depicts the analysis paths that provide the Aircrew with meaningful and useful knowledge.

The MSTF model automatically generates fused tracks in the mission computers for the aircrew to make quick tactical decisions. The fused tracks can be used for accurate detection of objects in the battle space.

The MSTF model consists of multiple sensors, trackers and multi-sensor correlation processor and the vehicle interface unit, and the aircrew. The multiple sensors provide sensor reports as the input vector to trackers, and the trackers generate the feature vector for the target. The feature vector indicates kinematics parameters, such as position vector, velocity vector and acceleration vector of detected targets. The multi-sensor correlation processor is used to compute the correlation coefficients between the tracks. The multi-sensor correlation processor is also used to discriminate tracks. The vehicle interface unit (VIU) serves as the communication between the Multi-Sensor Correlation Processor and the aircrew.

The output of the trackers, have the following feature elements inside each feature vector: {Latitude, Longitude, Bearing, Target Range, Range Rate, Ground Speed, Course or Direction, Altitude}. These feature elements are the tactical kinematics parameters that can characterize, detect and track targets. [Jeun, Whittaker, 2002]

#### **4 EXAMPLE OF MSTF MODEL**

Consider that the multi-sensor track fusion model consists of only two sensors and one is a radar sensor (radar tracker) the other one is IFF sensor (IFF tracker).

Example #1:

Suppose the radar tracker, computes a feature vector for track #1, denoted as T1:  $T1 = \{5.0, 10.0, 75.0, 60.0, 2.0, 150.0, 75.0, 20.0\}$  and suppose the IFF tracker, outputs a feature vector for the track #2, denoted as T2:  $T2 = \{10.0, 40.0, 85.0, 65.0, 2.0, 140.0, 65.0, 85.0\}$ . The correlation coefficient between the two feature vectors is equal to 0.87. Therefore the result of the fusion action is that the track #1 and track #2 are two distinct tracks.

Example #2:

Suppose the radar tracker, produces a feature vector for track #1, denoted as T3:  $T3 = \{30.0, 20.0, 60.0, 70.0, 2.0, 100.0, 60.0, 30.0\}$  and suppose the IFF tracker, defines a feature vector for the track #2, denoted as T4:  $T4 = \{30.0, 20.0, 60.0, 70.0, 2.0, 100.0, 60.0, 30.0\}$ . The correlation coefficient between the two feature vectors is equal to 1.0. Therefore the result of the fusion action is that track #3 and track #4 most likely characterize the same target

## 5 MULTIPLE TARGET ID FUSION (MTIDF) MODEL

The objective of the Multiple Target ID Fusion (MTIDF) model is to provide target identification information for the aircrew to make accurate decisions concerning target selection and target prioritization.

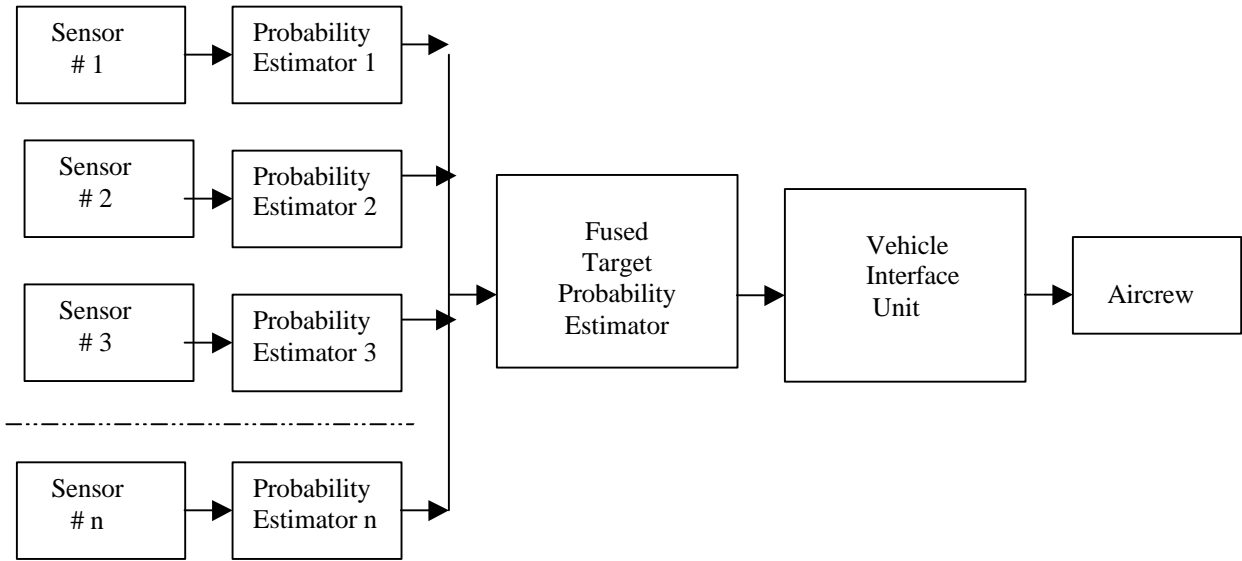

Figure 2: Multiple Target Identification Fusion block diagram shows the analysis paths that provide the Aircrew with meaningful and useful knowledge.

The aircrew can use the target identification information from the MTIF processor to accurately deploy weapons onto enemy targets. Most the smart aircraft with fusion technology, can clearly determine where the enemy aircraft are, in the multi-sensor and multiple target environment. The MTIDF model determines the fused target identification from the multiple targets.

The fused target probability for the multi-sensor and multiple targets can be expressed as:

$$P(T_k / S_1, S_2, S_3, \dots, S_n) = \frac{R(S_1/T_k)P(S_2/T_k) \dots P(S_n/T_k)}{\sum P(S_1/T_i)P(S_2/T_i) \dots P(S_n/T_i)} \quad (2) \text{ [Hall, 1992]}$$

Where  $P(T_k / S_1, S_2, S_3, \dots, S_n)$  is the probability of target  $T_k$  given in multi-sensor environment.

For a single sensor and multiple targets, the fused target probability reduces to the following:

$$P(T_k / S) = \frac{P(S/T_k)}{\sum P(S/T_i)} \quad (3) \text{ [Jeun, 1979]}$$

This expression is exactly the same as the probability of association.

## 6 EXAMPLE OF MTIDF MODEL

Figure 3 is used to illustrate the different views of two targets, T1 and T2 as seen by Sensor #1, Sensor #2 and Sensor #3. The basic question to be answered can be formulated as the following: “Are targets #1 and #2 observed by sensor #1, sensor #2 and sensor #3 the same target”?

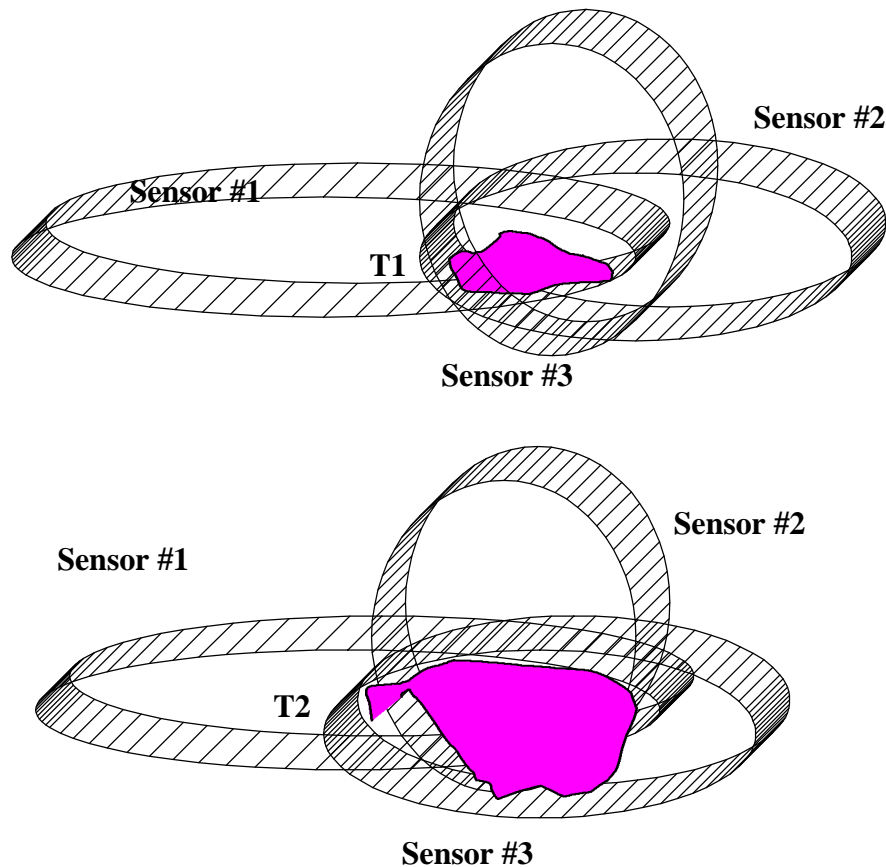

Figure 3: Potentially two targets as “seen” by three different sensors, where the colored regions indicate the fused target probability.

Application of the method shown in [Jeun, 1995] results in the following estimated fused target probabilities for the target set presented by Figure 3. The estimated fused target probability of target#1 (T1) is calculated to be  $P(T1/S1,S2, S3) = 0.20$  and the calculated fused probability of target#2(T2) is estimated to be:  $P(T2/S1,S2,S3) = 0.80$ . Because the fused probability of T2 is greater than the probability of T1, we therefore conclude that target #1 and target #2 are two distinct targets.

## 7 MULTI-SENSOR IMAGE FUSION MODEL

The objective of the Multi-Sensor Image Fusion model is to produce consistent images from multiple sensor images. The Multi-Sensor Image Fusion model block diagram in Figure 4 shows

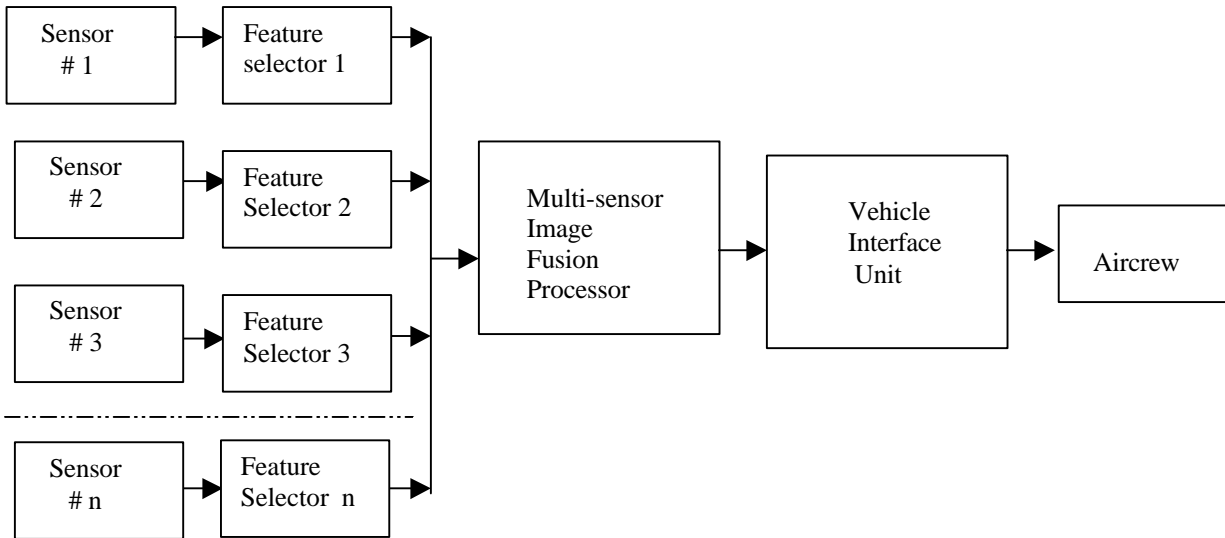

Figure 4: Multi-Sensor Image Fusion block diagram portrays the analysis paths that provide the Aircrew with meaningful and useful knowledge.

an example of processes that can be employed. The Edge Detector method and Coherence Change Detector method, and Fourier Descriptor method are widely used image analysis techniques. [Delp, Mitchell and Jain, 1986]

Multiple pictures, like images, can produce information overload, making it impossible to be interpreted by human mental processing. In order to reduce this information overload requires some automatic integration, or better yet, application of the multi-sensor image fusion technique to process the pictorial images.

## 8 EXAMPLE OF MSIF MODEL

To help understand the use of the MSIF model consider the objects pictured in Figures 5 and 6.

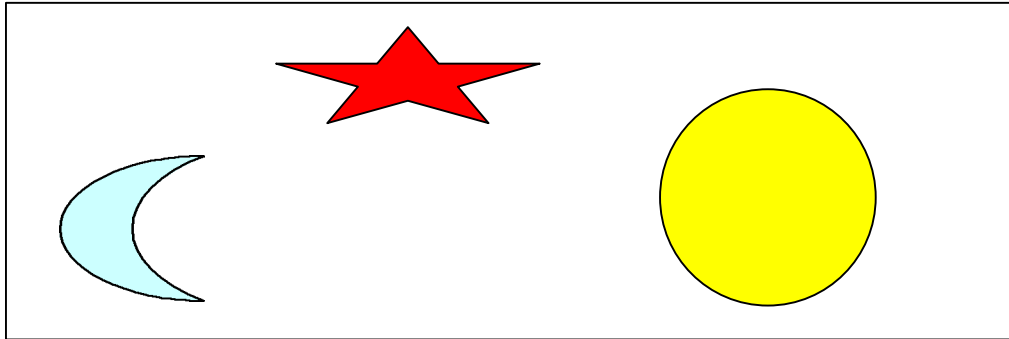

Figure 5: An first image with three distinctly shaped and colored objects, two of which are different from Figure 6 and one of which, the pale blue moon, is common to Figure 6.

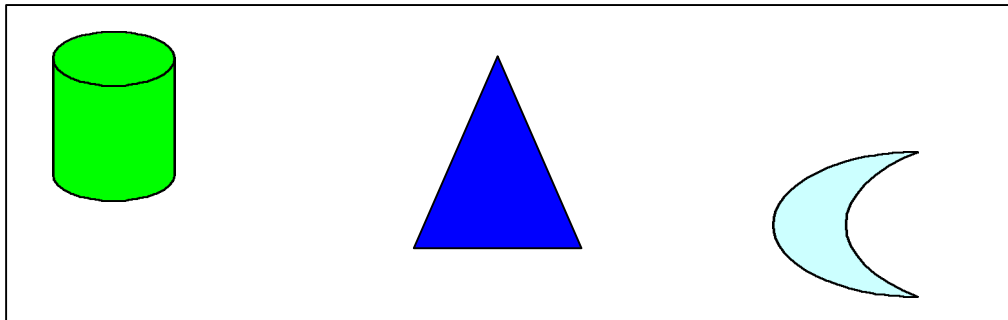

Figure 6: A second image with three distinctly colored and shaped objects, two of which are different from Figure 5 and one of which, the pale blue moon, is common to Figure 5.

Figure 5 contains the following images: (1) A red star with feature vector  $X_1 = \{0, 1, 7, 0, 5, 7, 3, 5, 1, 3\}$ ; (2) A pale blue moon with feature vector  $X_2 = \{1, 1, 1, 5, 5, 6, 7, 3, 3, 2\}$ ; and (3) A bright yellow sun with feature vector  $X_3 = \{1, 1, 1, 7, 7, 5, 5, 4, 4, 3\}$ . Figure 6 portrays the following images: (5) A dark blue triangle with feature vector  $Y_1 = \{1, 1, 1, 1, 7, 7, 7, 7, 4, 4\}$ ; (6) A pale blue moon with feature vector  $Y_2 = \{1, 1, 1, 5, 5, 6, 7, 3, 3, 2\}$ ; and (7) A bright green cylinder with feature vector  $Y_3 = \{2, 2, 0, 0, 4, 4, 6, 6, 4, 4\}$ .  $X_1$ ,  $X_2$ ,  $X_3$ ,  $Y_1$ ,  $Y_2$  and  $Y_3$  are obtained applying Friedman's code. [Fu, 1982]

The question that needs to be answered is the following: Can an Aircrew flying a smart aircraft, equipped with a MSIF model, positively identify the objects contained within the images presented by Figures 5 and 6?



The results from the Multi-Sensor Image Fusion model are:

- (1) The fused image pale blue moon appeared in both Figure 5 and Figure 6, because the correlation coefficient between  $X_2$  and  $Y_2$  is 1.0
- (2) The red star and bright yellow sun in Figure 5 are distinct objects. They have nothing in common with other images in Figure 5 and Figure 6, because:
  - (a) The coefficient of correlation between  $X_1$  and  $X_2$  is 0.69
  - (b) The coefficient of correlation between  $X_1$  and  $X_3$  is 0.54
  - (c) The coefficient of correlation between  $X_3$  and  $X_2$  is 0.91
  - (d) The coefficient of correlation between  $X_1$  and  $Y_1$  is 0.69
  - (e) The coefficient of correlation between  $X_1$  and  $Y_2$  is 0.58
  - (f) The coefficient of correlation between  $X_1$  and  $Y_3$  is 0.58
  - (g) The coefficient of correlation between  $X_3$  and  $Y_1$  is 0.77
  - (h) The coefficient of correlation between  $X_3$  and  $Y_2$  is 0.91
  - (i) The coefficient of correlation between  $X_3$  and  $Y_3$  is 0.66
- (3) The dark blue triangle and bright green cylinder are distinct objects. Again they have nothing in common with other images in Figure 6 and Figure 5, because:
  - (a) The coefficient of correlation between  $Y_1$  and  $X_1$  is 0.69
  - (b) The coefficient of correlation between  $Y_1$  and  $X_2$  is 0.81
  - (c) The coefficient of correlation between  $Y_1$  and  $X_3$  is 0.77
  - (d) The coefficient of correlation between  $Y_3$  and  $X_1$  is 0.58
  - (e) The coefficient of correlation between  $Y_3$  and  $X_2$  is 0.73
  - (f) The coefficient of correlation between  $Y_1$  and  $Y_2$  is 0.81
  - (g) The coefficient of correlation between  $Y_1$  and  $Y_3$  is 0.88
  - (h) The coefficient of correlation between  $Y_3$  and  $X_2$  is 0.66

## 9 CONCLUSIONS

- (1) Multi-sensor integration is widely accepted as a technology that is ready to be used in product development and production environments.
- (2) Personnel need to become knowledgeable in fusion technology so that it too can be applied in these environments.
- (3) The examples of the Multi-Sensor Track Fusion model, the Multiple Target Identification Fusion model and the Multi-Sensor Image Fusion model used simulated information. Nevertheless, only a smart aircraft equipped with these models can quickly and positively identify the objects contained with the images contained in Figure 5 and Figure 6.
- (4) The fusion techniques outlined in this paper were mathematically proven. However, further testing with real time sensor input data is required before they can be applied to real world problems.
- (5) The fused track, fused target ID and fused target image are all expressed in a multi-dimensional feature vector. The algorithm developer and the software engineer, who work with fusion technology, need to be knowledgeable in the mathematical processing techniques.

## 10 REFERENCES

- 1 [Jeun, Whittaker, 2002] Buddy H. Jeun and Allan Whittaker, *Improve Strike Capability With The Statistical Pattern Recognition Technology*, National Fire Control Symposium, Seattle, Washington, 2002.
- 2 [Jeun, 1999] Buddy H. Jeun, *Application Of Neural Network, Statistical Pattern Recognition And Fusion Technologies To The Multiple Target Classification Problem*, National Fire Control Symposium, Colorado Springs, Colorado, 1999.
- 3 [Jeun, 1997] Buddy H. Jeun, *A Multi-Sensor Information Fusion Model*, Joint Service Combat Identification Conference, San Diego, California, 1997.
- 4 [Jeun, 1995] Buddy H. Jeun, *An ID Fusion Model*, Joint Service Combat Identification Conference, Monterey, California, 1995.
- 5 [Hall, 1992] David Hall, *Mathematical Techniques In Multi-sensor Data Fusion*, Artech House Publish Company, New York, 1992.
- 6 [Jeun, 1979] Buddy H. Jeun, *Design And Implementation Of Statistical Pattern Recognition Model*, Ph. D. Dissertation, Collage Of Engineering, University of Missouri-Columbia, Missouri, 1979.
- 7 [Delp, Mitchell and Jain, 1986] Delp, Mitchell and Jain, *Machine Vision*, School of Electrical Engineering, Purdue University, West Lafayette, Indiana, 1986
- 8 [Fu, 1982] S. K. Fu, *Syntactic Pattern Recognition and Application*, Prentice Hall, New York, 1982