

# **A Conceptual Operational Model for Command and Control of International Missions in the Canadian Forces**

By

Larry Cochran  
FirstMark Technologies Ltd.  
Ottawa, Ontario  
and

Kendall Wheaton  
Canadian Forces Experimentation Centre  
Department of National Defence  
Ottawa, Ontario

Defence Research and Development Canada – Valcartier has sponsored the development a Conceptual Operational Model of the strategic planning process within the Canadian Forces Joint Staff. This model is intended to convey an understanding of the processes within the headquarters for planning and monitoring international missions. As such, it captures the command and control processes at the strategic level of the Department of National Defence.

The objective was to construct an IDEF process model. An IDEF model is, however, a rather abstract representation and is not easily interpreted by itself. Therefore, the process adopted was to apply the information from surveying the Joint Staff in constructing three different views that contribute to the construction of an IDEF model. The first step was a simple context model that shows a single process (Plan development) and the primary interfaces with that process. The context diagram was supplemented with an activity diagram that breaks the process down into discrete activities and allocates those activities to the organizational elements. The third view constructed was a hierarchical view of the activities that provides a structured and more detailed breakdown of the activities. The three views of the planning process provide most of the information, in an easily understood form, that can be applied to the construction of an IDEF model.

The model describes the process activities, objects and attributes necessary to enable an evaluation of the headquarters process. The model enables the identification of target organizational cells for which new tools may be offered to improve the effectiveness of specific activities, such as mission planning, or to improve the quality of the products of those activities. The Canadian Forces organization is large, includes many resources and carries out a wide range of activities in support of Canadian national interests. The Conceptual Operational Model is the first step in the development of new support tools specifically in the domain of situation awareness and strategic planning.

## Introduction: Managing Complexity

With the emergence of network centric warfare has come increasing complexity in managing command systems to cope with the operational requirements of fielding task-tailored combat-ready forces in a global environment in which each operation appears to be a custom-tailored affair. Fielding adaptive collaborative command systems at a moments notice to suit the coalition-specific organizational environment is a continuing and daunting challenge as we charge into the 21<sup>st</sup> century. The demand for new operational capabilities is accelerating at roughly the same rate as technology is developing. The rapid pace of change generates new ideas that can be quite distracting and very costly if they don't pan out. Change, while it tempts us with the promise of newer, faster methods of doing things, can be disruptive and counterproductive unless the changes are implemented in a coordinated and integrated fashion. New capabilities need to interoperate with existing capabilities and across multiple organizational boundaries affecting many stakeholders. Implementing multiple new capabilities in parallel requires great discipline, collaboration and cooperation among stakeholders. Unfortunately, discipline, collaboration and cooperation among stakeholders often translates into bureaucratic procedures and costly delays that ensure new capabilities are obsolete by the time they are deployed. The Canadian Forces, as do all others, have an urgent need to be able to roll out incremental operational capabilities quickly. The work reported herein, describes a modeling approach to contribute toward that goal.

The greatest risk in managing evolutionary systems is establishing a common understanding between stakeholders. Failure to understand concepts, objectives, priorities and expected outcomes is the largest obstacle in the path between concept and deployment. The magnitude of the risk is directly related to the number of stakeholders and the number of interfaces involved.

An operational model is an effective and essential element of developing a common understanding between operators, architects, developers and project managers. Having said that, the next issue is deciding which modeling technique to apply. Two of the leading contenders are:

1. IDEF Business Process Model, and;
2. Unified Modeling Language (UML).

IDEF is an acronym for *I-CAM Definition Methods*. I-CAM is the acronym for *Integrated Computer-Aided Manufacturing*, a U.S. Air Force project to develop methods for improving manufacturing productivity through the use of computer technology.<sup>1</sup>

IDEF, rooted in the manufacturing environment, has matured since its emergence as a standard in the 1980's, progressing to a much more sophisticated modeling language, capable of high fidelity representation of interactive processes. However, the software industry, following Object-Oriented methods, has largely adopted UML for capturing requirements and developing applications. The dominant modeling language for developers today is UML<sup>2</sup>. UML has become the standard for the development community today because it is derived from and is consistent with object-oriented development methodologies. Most IT and geospatial standards today have adopted UML as the modeling language for use in expressing standards.

UML tools are also well integrated with the tools of the development environment, facilitating the transition from requirements modeling to the code development and ensuring traceability between requirements and code. While UML is well suited to the development environment, its abstract nature and complex graphical notation make it difficult for operational managers to grasp. The jargon of UML is the jargon of developers. At the business process level operational managers tend to find the IDEF convention easier and quicker to grasp. The jargon of IDEF is still rooted in the operational environment.

The IDEF business process technique was chosen to model at the enterprise level with the expectation that UML would be more effective at the application development level where there is a great deal of interaction between the individual operator and the system user interfaces. Before delving into the highly detailed and interactive application level it is necessary to establish an enterprise level model that portrays principal business processes and is based on guiding documents such as:

1. Strategic departmental documents;
2. Operational doctrine, and;
3. Standard Operating Procedures.

If the primary objective of an operational model is to establish a common understanding between stakeholders, then three conditions are essential:

1. The model should present information at an appropriate level. Too much detail will be distracting and divisive.
2. The model must relate closely to the guidance documents identified above. It is essential that the key guidance documents be directly accessible from the graphical elements of the model. Guidance information at hand is necessary to develop understanding and to identify and clarify issues when changes to doctrine and SOPs are being planned.
3. The language used in the model must be in the language of the operators, rather than the language of architects and developers.

The IDEF business process modeling technique has proven to be an effective method for describing operational processes. The simple diagramming language is quickly grasped and understood. It conveys a level of information appropriate for expressing business processes. The original function modeling method, IDEF0, has spawned an integrated set of methods for comprehensive systems engineering and development:

IDEF0	Function Modeling method
IDEF1x	Data Modeling method
IDEF3	Process Flow and Object State Description Capture Method
IDEF4	Object-Oriented Design Method
IDEF5	Ontology Description Capture Method

IDEF3 is an appropriate method for use in the COP21 operational model because it captures the behavioral aspects of systems rather than simple sequential functions.<sup>3</sup>

The diagram in Figure 1 below illustrates the basic convention of the IDEF3 Model, with the processes involved in a paint operation, which includes a quality check and re-work, if necessary.<sup>2</sup>

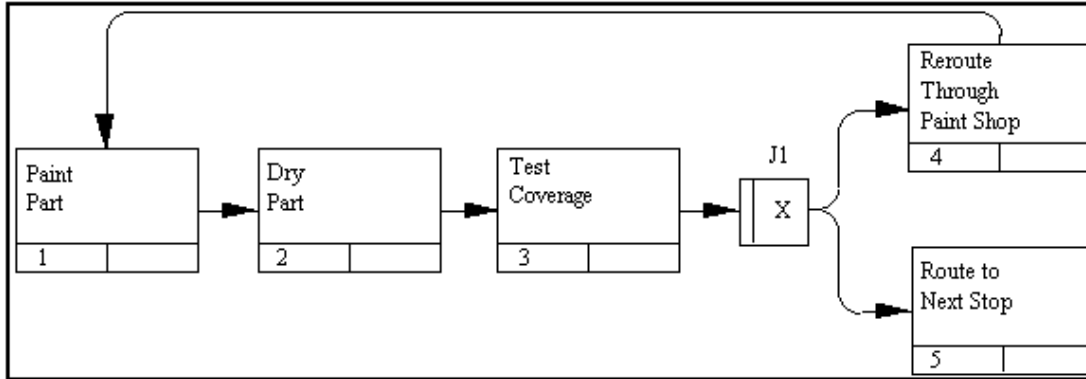

**Figure 1: IDEF Model Convention**

The simple elements of Inputs, Outputs, Controls and Supporting Mechanisms enable most of the needs of the business process to be captured. Associated with each element (Arrow entities and Box activities) is information that describes the entity or activity.

### The Modeling Process

The COP21 Conceptual Operational Architecture project modeled the processes of the Joint Staff at Canada's National Defence Headquarters. The focus was on processes related to operations planning and acquiring situation awareness. For the sake of brevity the following paragraphs describe the approach using a few examples of products resulting from the work.

It is difficult to construct a model in a single step. There are too many entities, interfaces and relationships to understand and cope with at a single stroke. A set of simple, differing views often produces the understanding required to construct a more effective model. The objective is to construct an IDEF process model, but starting with an IDEF model is probably not the most constructive way to achieve that result. The process adopted in this case is to apply the acquired information in constructing three different views that contribute to the construction of the IDEF model. The first step is a simple context model that shows a single process (Plan development) and the primary interfaces with that process.

The context diagram is supplemented with an activity diagram that breaks the process down into discrete activities and allocates those activities to the organizational elements, or individual actors. The sequence of activities shown in the diagram describes the timing of the activities.

The third view constructed is a hierarchical view of the activities that provides a structured and more detailed breakdown of the activities.

With the three views of the planning process, we have most of the information, in an easily understood form that can be applied to the construction of an IDEF model.

### Context Diagram – Strategic Planning and Situation Awareness

The context diagram shown below [Figure 2] provides a simple perspective of the planning function, yet illustrates important concepts and relationships.

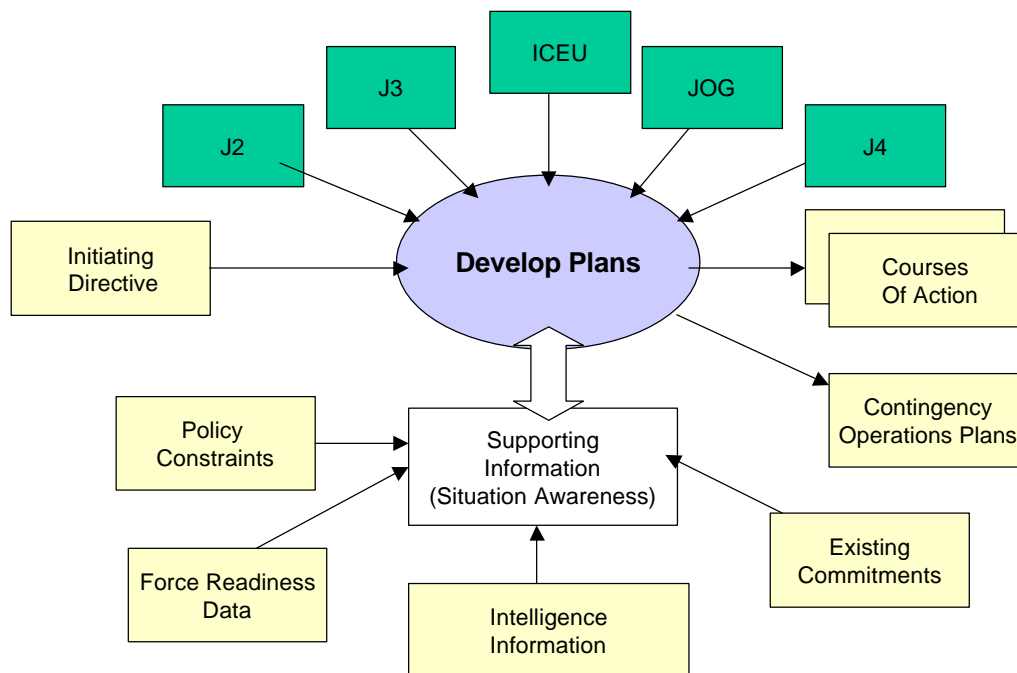

**Figure 2: Context Diagram Planning**

For instance, the trigger event is the initiating directive and the outputs are Courses of Action (COAs) and Contingency Operations Plans (COPs). There are other intermediate products, but these are the primary products of the planning process. The diagram also illustrates that there is a wide variety of information that supports the planning process, some of which is generated as a result of the planning activities.

The third fundamental concept illustrated by the context diagram is the key participants, or actors, in the organization that contribute to or perform planning activities.

With regard to supporting information, the diagram illustrates that it is the supporting information that provides situation awareness when the information is accessible by the planning personnel. Furthermore, situation awareness includes not only intelligence about the adversary (red forces), but also information about the environment, as well as information about CF and coalition assets.

This context diagram also enables the cataloging of actors, activities, and of entities and attributes associated with those entities.

It is also worthwhile to point out that the planning process is a continuous process that spans the operation from inception to completion and redeployment following the operation. At the strategic level, the actors, activities, tools and processes are either the same or a subset of the total activities for each of the five phases of the operation. Therefore, getting the process of planning and working effectively with situation awareness provides effective results through the life of the operation.

### **Activity Diagram – JSAT Peace Support Planning Scenario**

The diagram shown below is a high-level activity diagram that illustrates the Joint Staff Action Team (JSAT) process applied to the typical United Nations (UN) peacekeeping support scenario. The activity diagram illustrates the sequence of activities and the roles of each of the organizational elements in the process. Each actor is assigned to one of the “swimlanes”. The timing of the sequence is indicated in the vertical dimension.

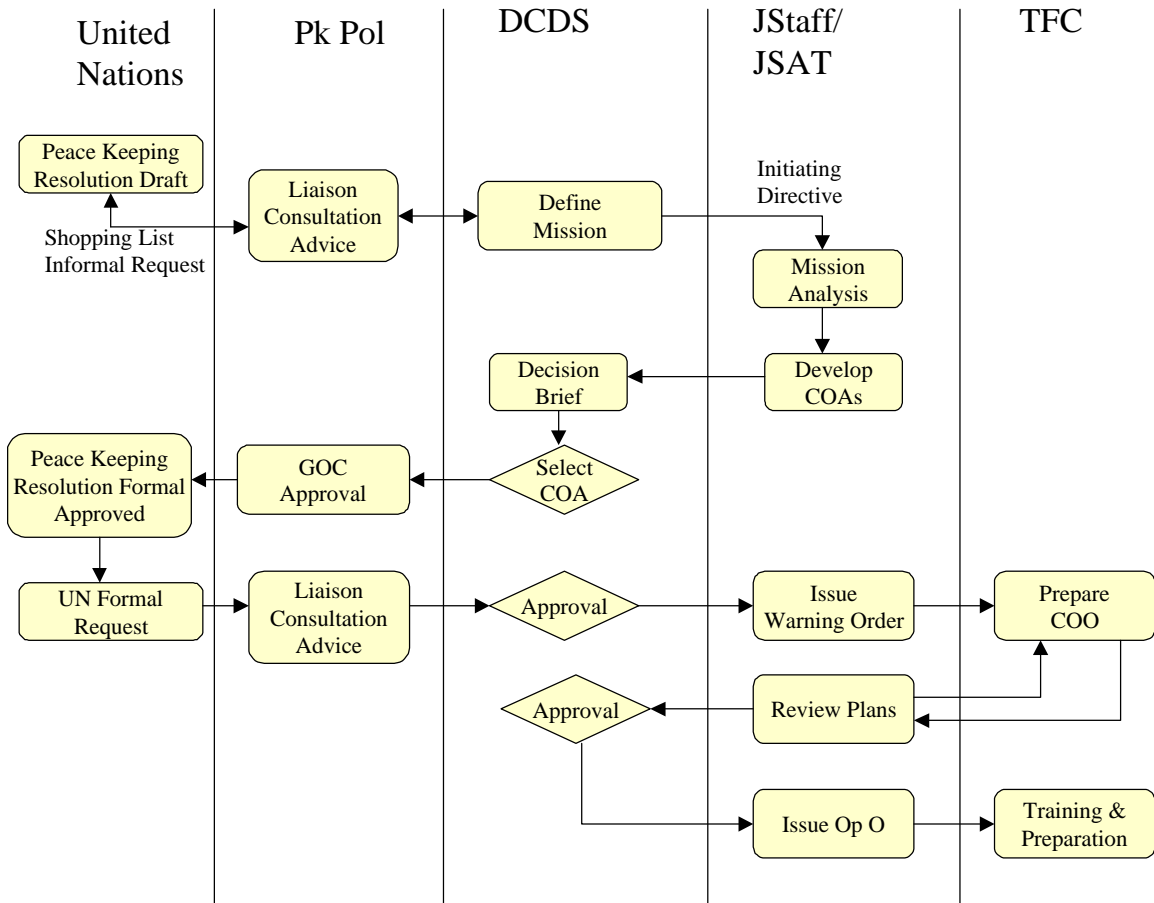

**Figure 3: Activity Diagram Planning for Peacekeeping Support**

The period of time from the request from the UN through COA development to the Decision Brief may be a few days to several weeks. The typical time from approval and issue of the Warning Order to the issue of the Operations Order (Op O) may two to four months because of the effort required to do the detailed operational planning. The issue of Warning Orders is consistent with the DCDS appointing a Task Force Commander who assumes responsibility for the development of the operational plans. The JSAT continues to support the TFC through the planning process. Once the Op O has been issued, COS J3 staff officers support the mission throughout the operation.

The activity diagram shown in Figure 3 is a UML-style diagram used to capture operational concepts. Using the UML activity diagram in conjunction with the IDEF process model adds useful information to the IDEF model while building a bridge between IDEF and UML for the developer community. The activity diagram conveys an understanding of related activities that complements the hierarchical decomposition style of the IDEF model. Taken together, the observer may acquire a better understanding of the operational concepts than by viewing just one or the other.

## Hierarchy of Activities

All of the above information leads to the ability to construct a list of activities in a hierarchical fashion that allows more detailed activities to be added incrementally as knowledge of the model grows. Figure 4 illustrates a hierarchy of activities for the strategic planning process, which includes the participation of the cells of the J Staff.

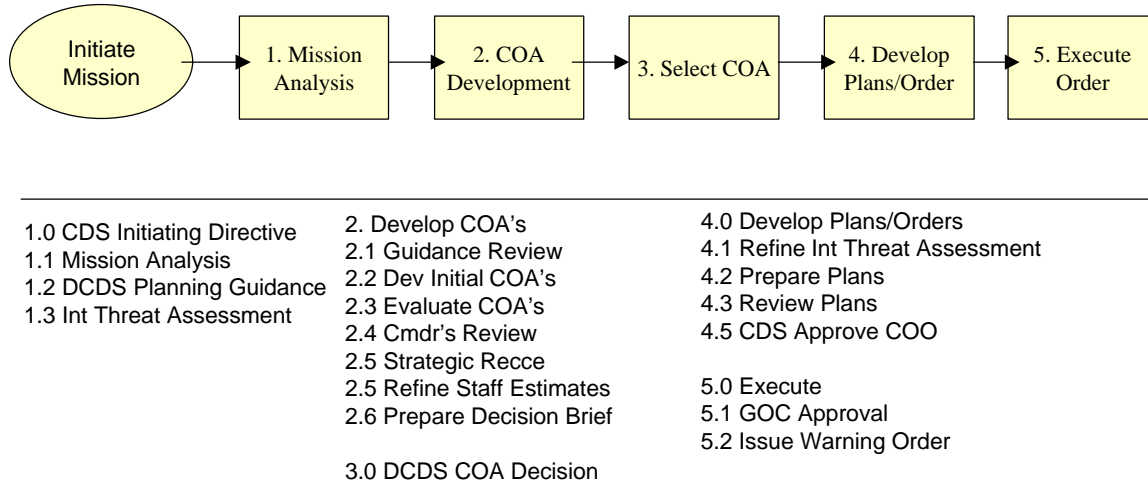

**Figure 4: Hierarchy of Planning Activities**

The simple hierarchy view provides a guide for decomposing the IDEF processes into subordinate activities. It serves as a checklist for completeness.

The combination of the three views (Context, Activity, and Hierarchy) provides an effective method for managing and supporting the development of the IDEF model. The three views also provide complementary information that is easily included in the process description within the IDEF model.

## IDEF Process Model

Modeling in the IDEF convention is a decomposition process in which the principal mission-specific process is decomposed into lower level sub-processes. The figure below [Figure 5] is the A0 Enterprise activity for the Canadian Forces. The mission of the CF is to defend Canada and Canadian interests. The activities of the CF are constrained by legislative regulations and policies, the global environment and by the policy that requires the CF to operate internationally with allied governments. The inputs to the CF enterprise consists of government strategic direction, specific operational taskings, and funding for operations and capital expenditures. The CF also receives information from non-CF sources including Canadian and coalition intelligence, surveillance and reconnaissance sources. The products, or outputs of the CF enterprise include completed missions, business plans, management reports and responses to information requests as well as support for other government departments and programs.



The CF also provides support to allied and coalition operations. In the conduct of those operations, the CF may utilize supporting resources from coalition force capabilities.

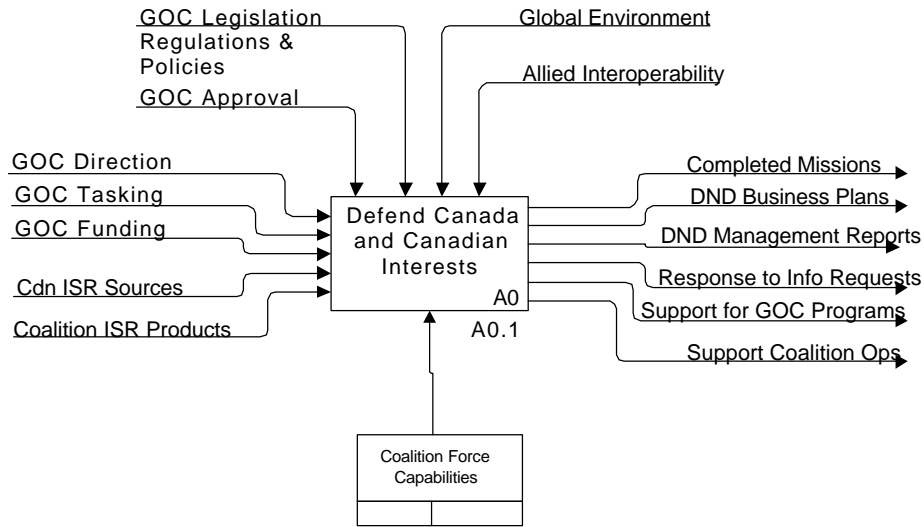

**Figure 5: Top Level (A0) Enterprise Activity for the CF**

The diagram expresses the enterprise mission of the CF quite well. However, the decomposition of the subordinate activities requires some careful consideration.

There is more than one enterprise view of DND. One view is expressed in the CF Force Employment Manual (FEM)<sup>4</sup>. The Forward section of the FEM introduces a model that defines four core processes. A more recent model, CF Ops Enterprise Model<sup>5</sup>, defines the core processes in a significantly different manner. It is worthwhile to examine the two models to ascertain the different approaches.

### The CF FEM View

The CF FEM view is described in the forward of the FEM, and in more detail in Chapter 7 of the FEM. This four core process (4CP) model was developed in 1990's by the Management Command and Control Re-engineering Team (MCCRT), an internal review process sponsored by the Department of National Defence. The node tree diagram of the IDEF model is shown below.

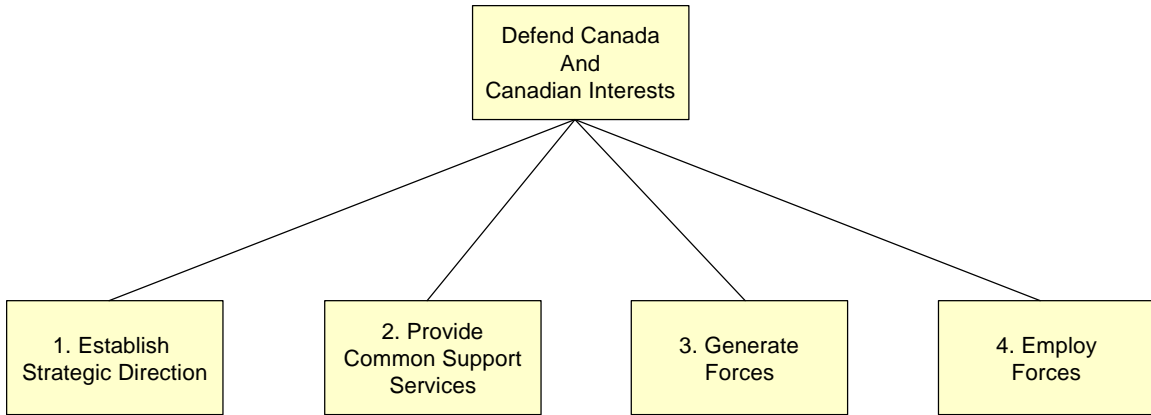
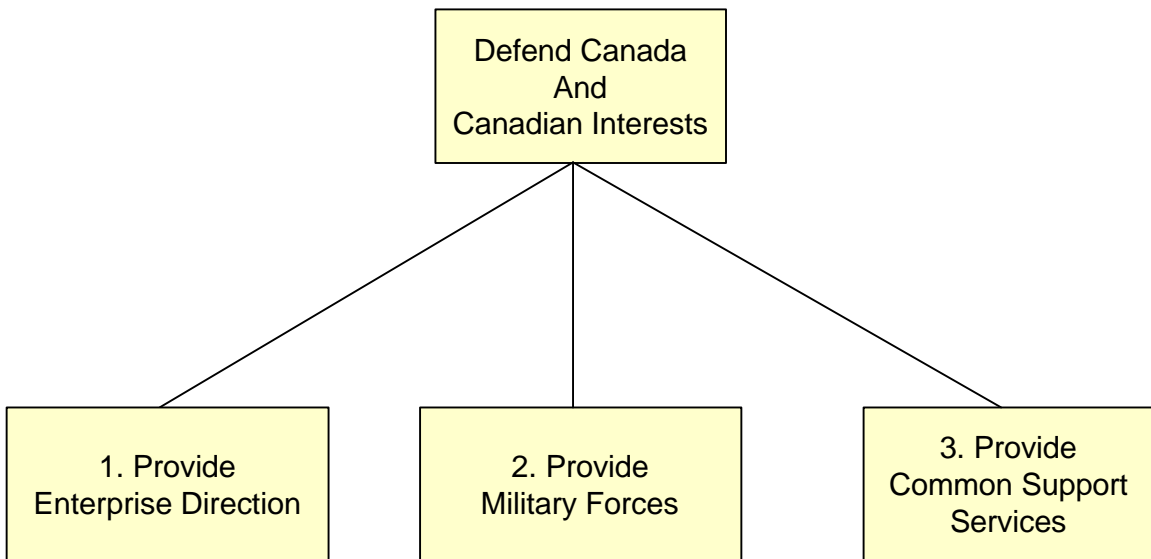

**Figure 6: The MCCRT Four Core Process Model**

The definition of activities allocated to each of the four core processes yields insight into the rationale for the decomposition of the mission into the four processes. The rationale expresses a high-level *sequential process view of the organization* from strategy through preparation to execution.

**The CF Ops Enterprise View**

The CF Ops Enterprise model constructed more recently, is based on a three core process view of the same lower level processes as in the CF FEM view:



**Figure 7: Three Core Process Model**

The allocation of principal activities to the core processes expresses an enterprise view that *recognizes that the CF organizes and conducts operations on strategic, operational, and tactical levels*. Furthermore, Enterprise direction is more than strategic direction and is not well expressed in the four core process model. Another motive is the implementation of the OODA loop at each level of the organization and operation. OODA is the Observe, Orient, Decide and Act repetitive sequence that indicates that the planning and execution of activities occurs all across the organization and occurs continuously within an operation through each of the five phases of the operation.

Inspection of the more detailed activities in the 4CP model shows that they can be mapped into the activities of the 3CP model. For instance, in the 3CP model, the process “Provide Military Forces” includes the major elements of Force Generation and Force Employment in the 4CP model. In the 3CP model the activities related to capability planning have been allocated to the Enterprise Direction process. The important strategic, operational and tactical levels of operation are expressed at the highest level of the decomposition.

It is the view of the writers that the decomposition of the 3CP model better reflects the most important organizational and operational characteristics of DND than does the sequential flow rationale of the 4CP model.

However, the 3CP model, at the outset of this project was not populated, beyond the identification of the process structure and interconnecting arrows. The major portion of the work of the project has been populating and adapting the 3CP model from the information contained in the CF doctrine manuals and SOP’s, supported by the interviews with the Joint Staff at NDHQ. The populated enterprise model can be used for concept development and experimentation leading to new operational capabilities for strategic planning and situation awareness.

The preceding discussion underscores the importance of understanding the enterprise before beginning the modeling process. The first step in decomposition will have great impact on the way in which the model is interpreted. It also underscores the significance of explaining to the stakeholders the rationale for the chosen approach to decomposition.

## **Decomposition of Level 1 Activities**

To make the preceding discussion meaningful it is useful to present the level one activities for each of the three core processes. The business process A1 Provide Enterprise Direction is decomposed and illustrated in Figure 8. The core business process A2 Provide Military Forces is decomposed and presented in Figure 9. The third core business process A3 Provide Common Support Services is decomposed and presented in Figure 10.

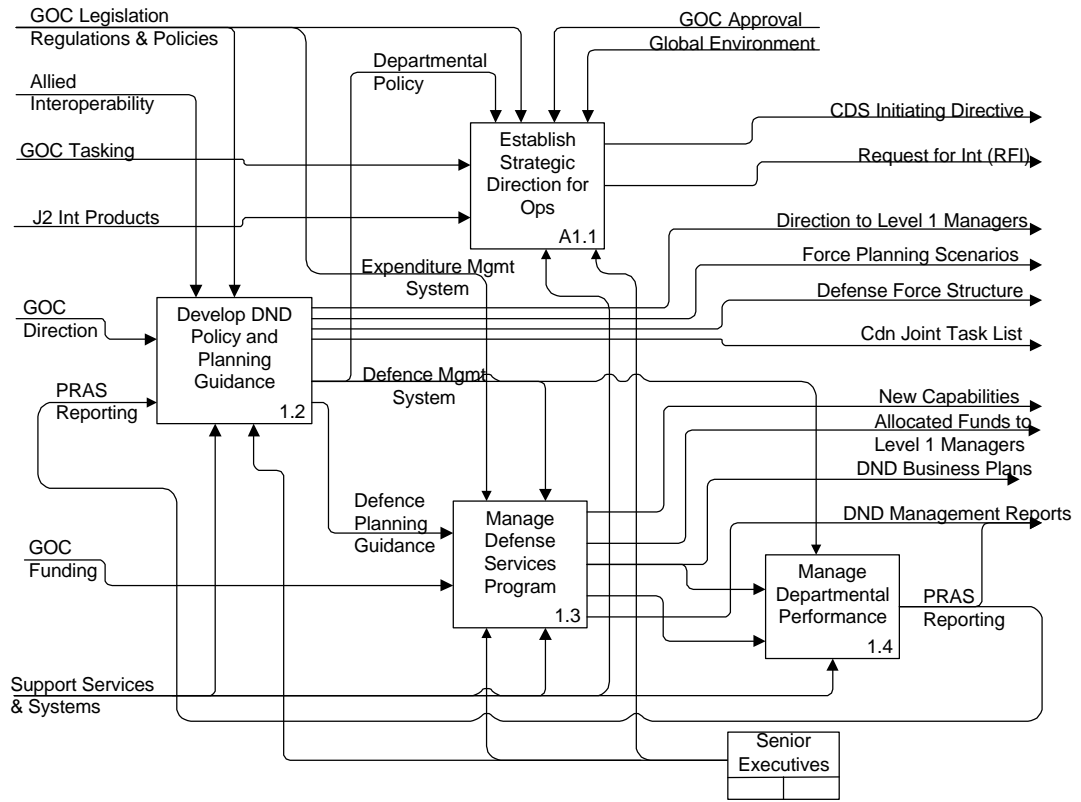

**Figure 8: A1 Provide Enterprise Direction**

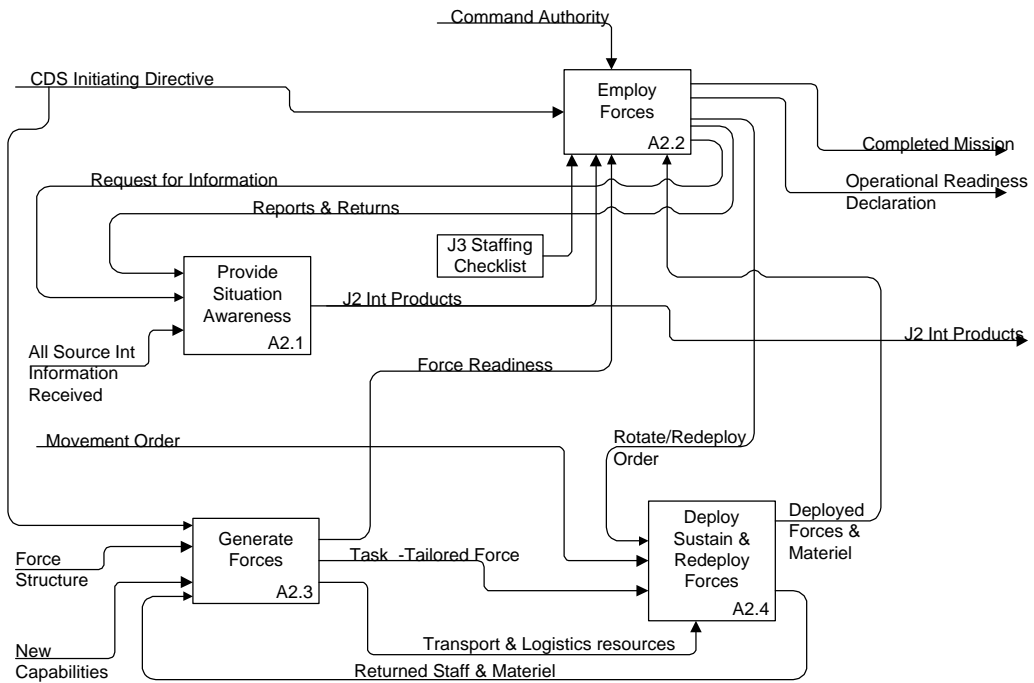

**Figure 9: A2 Provide Military Forces**

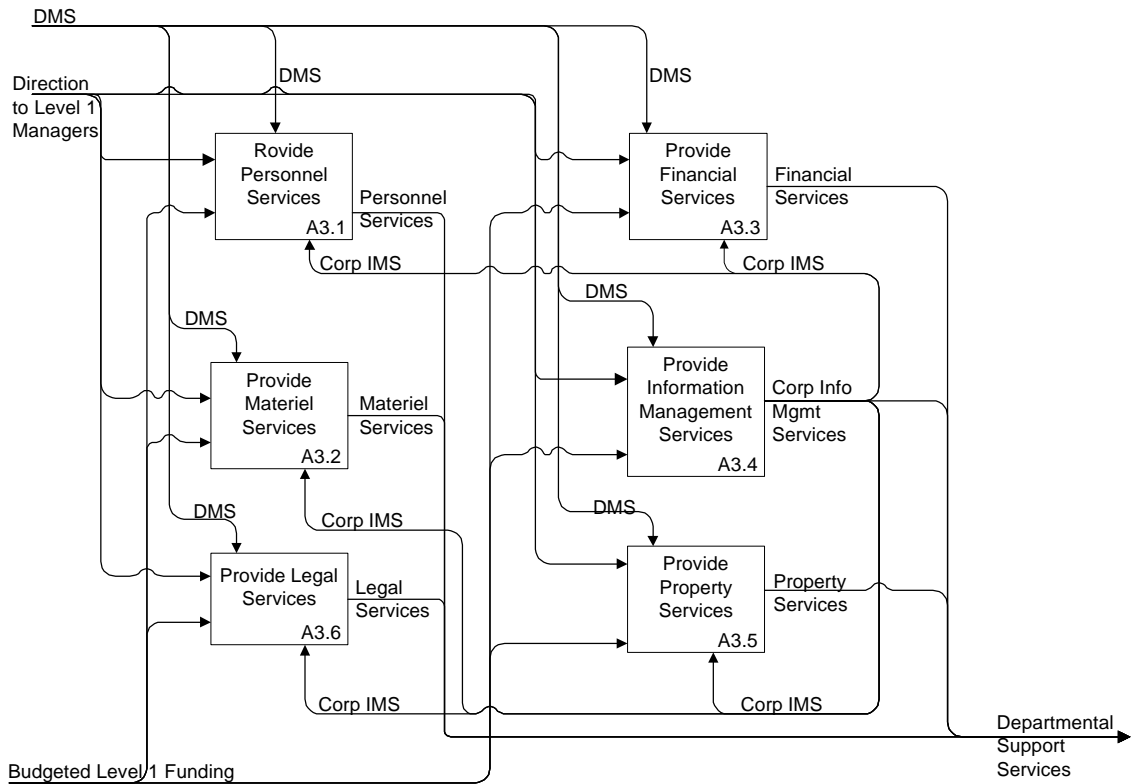

**Figure 10: A3 Provide Common Support Services**

The three Level 1 diagrams are indicative of how quickly the decomposition process can become complicated and why it is necessary to give careful thought to the organization and approach to decomposition. If too many activities are allocated to a given level in the diagrams, it gets messy and unmanageable. There is a significant element of art involved in the practice of decomposition. It is important for the modeler to understand the needs and objectives of the stakeholders in order to provide a model that will meet their needs.

It will be obvious to some observers that some details may be missing from the diagrams. Modeling is an evolutionary and incremental process. Seldom is a model called complete. It is also important for models to be embraced by the stakeholders, for them to participate in the construction and validation of the model. Otherwise, they will fail to understand the model, will not take ownership of their portion of the model and will be less likely to make good use of it.

## Supporting Documentation

Contrary to popular belief, the reason for constructing operational models is not to provide employment for OR scientists, but rather to enable stakeholders who are not OR scientists to engage the model in order to examine, understand and evaluate new concepts. A model that sits on the shelf collecting dust is not effective. A model created by a proprietary tool that prevents unlicensed users from interactively engaging the model is of limited value. Furthermore, a proprietary tool that provides only a limited capability to attach supporting documentation to the graphical elements imposes a handicap on the modeler and the intended audience. With these issues in mind, the expensive proprietary tools were abandoned in favor of a more accessible and open approach. The model has been implemented in an HTML environment using Microsoft Visio as the graphic tool with IDEF and UML templates and a broad set of universal graphic symbols. Microsoft Word and Adobe text editors have been employed because virtually all of the supporting documents are either in Word or PDF format. Macromedia Dreamweaver has been used as the HTML editing environment to create the model in the form of a web page. The IDEF model as a web page application provides universal access to all of the stakeholders and incorporates a rich resource library of supporting documents that are directly linked to each of the graphical objects in the diagrams. Each of the stakeholders can engage the model and contribute to its evolution from their own desktop without acquiring an expensive single purpose license for IDEF modeling.

An invaluable tool for the modeler as well as the stakeholders is a comprehensive index of terms which provides a cross reference for all the supporting documents and a local search tool. Having the capability to locate every reference to a specific term is necessary for completeness and for addressing issues and conflicts. Equally valuable is a common glossary that establishes a valid definition for important terms. The web page format also provides a list and links to each of the reference documents for direct access, enabling users to get at the documents directly or through the graphic model.

The model has been constructed in modular sections to enable different stakeholder groups to edit and extend a portion of the enterprise model specific to their interests. For example, the activities related to Provide Situation Awareness A2.1, Figure 11, are another section of the enterprise model. Situation awareness is primarily the domain of intelligence and the NDCC. They are the actors who are responsible for the SA processes and recourses and it is they who should take ownership of the SA business process segment of the enterprise model. In like manner, Enterprise Direction activities, Figure 12, are the responsibility of senior leadership in the Joint Staff. IM services that support human resources may not be of particular interest to C2 types, but operations cannot be planned and executed without input from HR and medical support groups. Command systems exist and operate in the context of an enterprise, each element of which has an important role to play in the mission of the enterprise. The segmentation of the enterprise model facilitates stakeholder participation with the expectation that stakeholders will participate, contribute and take ownership of their respective segments of the model. Such models are alive and active, not sitting on the shelf.



Finally, the web page model environment includes pages for issues and concepts to be expressed outside the model. These pages support working groups of stakeholders to enable them to express views in such a way that all stakeholders can be aware.

## **Operational Architecture**

The discussion to this point has been about the construction of an enterprise operational model. The operational model, however, does not directly express an operational architecture. Architecture is about patterns. Just as a building design is based on structural patterns to achieve strength and flexibility of use, operational architectures should allow organizations to establish operational patterns across the breadth and depth of an organization. The OODA loop is a pattern that is common to most military organizations. The value of patterns in an organization is achieved in the ability to move people from one position to another with minimal time and effort required to adapt to the new responsibilities or new environment. Consistent operational patterns are essential to developing joint force capabilities. Similarly, operational interoperability between members of a coalition force requires consistent operational patterns in each organization to develop unity of force and to maintain synchronization in planning and conduct of operations.

The operational model does not directly indicate there is an architecture inherent in the way the organization behaves. Architecture implies patterns, but the patterns may not be evident in the model. Once the operational model is constructed, it may be possible to identify operational patterns.

In this COP 21 Conceptual Operational Architecture project, the operational architecture revealed by the examination of the operational model expresses three nested operational loops (OODA) with a common core service, Provide Situation Awareness. The diagram [Figure 13 ] illustrates the operational architecture revealed by the operational model. Examination of the operational model reveals the extent to which the doctrine and SOPs support a conceptual operational architecture. The process of examination may yield good insight to possible conflicts in the doctrine that inhibit the desired consistent operational behavior.



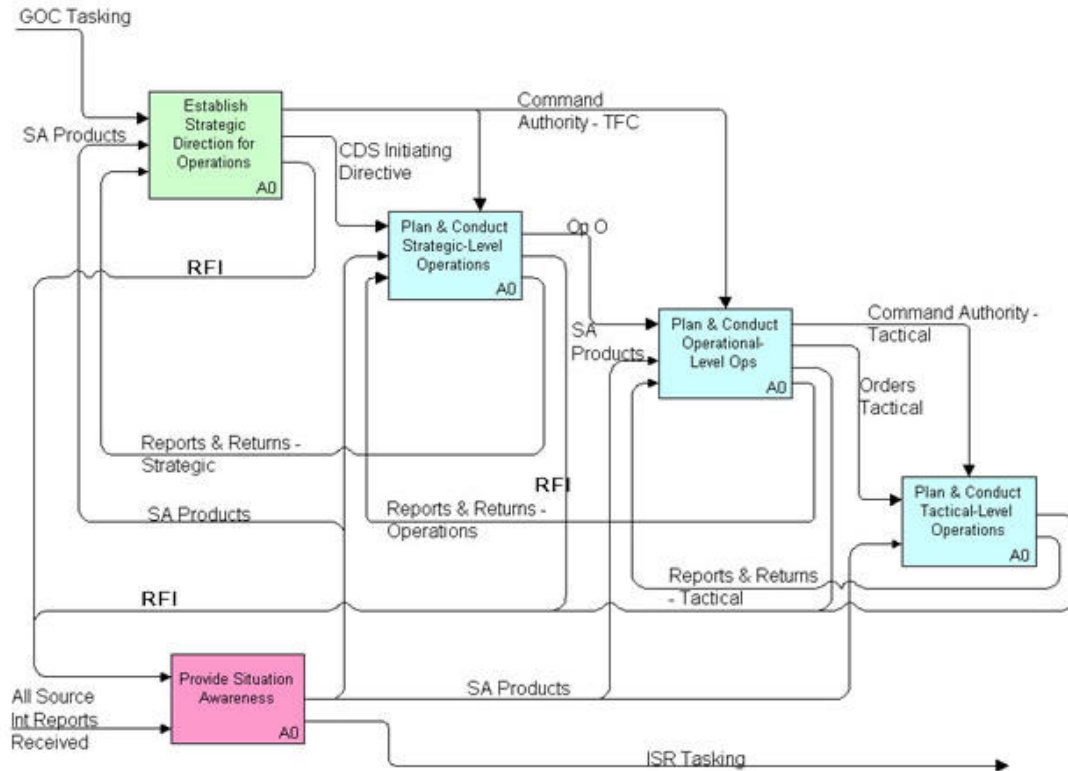

**Figure 13: Operational Architecture**

### **The way ahead – from network-centric to architecture-centric**

If the command system is viewed as an infrastructure of network services (as in “network centric warfare”), then the operational architecture is an essential element in identifying core and common services that support multiple organizational units and utilize common and consistent data. The operational architecture is a product of the operational model and should be the basis for evaluating or modifying doctrine, for identifying and specifying new operational capabilities, and for managing the evolution of the command system. The network should be transparent and the future should be seen as “architecture-centric warfare.” Operational modeling and operational architectures point the way forward, lighting the way for managing the complexities of open, distributed command systems in the 21<sup>st</sup> century.

## References

1. Integration Definition for Function Modeling (IDEF0), Draft Federal Information Processing Standards Publication 183, Dec 21, 1993, See also [www.idef.com](http://www.idef.com).
2. The Unified Modeling Language User Guide; Booch, Rumbaugh and Jacobson, Addison Wesley, ISBN 0-201-57168-4, 1998
3. Information Integration for Concurrent Engineering (IICE) IDEF3 Process Description Capture Method Report, Knowledge Based Systems, Inc. September 1995
4. Canadian Forces Force Employment Manual, B-GG-005-004/AF-004, June 6, 1998
5. CF Operations, Enterprise Model, Maj Eric Hermanssen