

# Intelligent Nodes in Coalition Warfare

**Edward Dawidowicz,**

U.S. Army Communications-Electronic Command (CECOM),  
Research Development and Engineering Center (RDEC)  
Fort Monmouth, NJ

<mailto:edward.dawidowicz@mail1.monmouth.army.mil>

**John Langston**

Austin Info Systems INC  
Austin, Texas

[langstoj@swbell.net](mailto:langstoj@swbell.net)

## Abstract

Just the recognition that 'knowledge is power' is not sufficient to utilize available information and transform this information into the powerful asset we call **knowledge**. With a continuous increase in the complexity and tempo on the modern battlefield; new demands are placed on rapid and precise information dissemination. The volume of information available to the user becomes larger while the time necessary to correctly interpret and understand this information becomes prohibitively smaller. Cognitive processing of information at the receiving nodes is a potential solution to this information overflow problem. These nodes we will call Intelligent Nodes [Dawidowicz, 2001]. This paper will introduce the architecture of an Intelligent Node and will demonstrate its hierarchical scalability across all echelons and Battlefield Functional Areas. This technology is also directly applicable to the Objective Force and Future Combat Systems.

**Keywords:** *Objective Force, Coalition forces, symbol grounding, Command, Control, Communications, Computers, Intelligence Surveillance and Reconnaissance, (CAISR), Network Centric, Knowledge Centric, actuation, behavior generation, commander's intent, conceptual graph, functioning, knowledge representation, battlefield, behavior generation, entity-relational network, heterarchy of organization, knowledge, knowledge management, messages, plan execution, and semantic network*

## 1.0 Introduction

The concept of Network Centric Warfare is a natural continuance dictated by technological advances in the areas of computing and network communications coupled with an always-present decision-makers' desire for having the right information at the right time. It is also recognized that the amount of information available could become a burden for the decision-maker, as the time required in making a decision is diverted for the tedium of information processing.

To resolve this problem intelligent assistants or agents are essential to help decision-makers with information processing. A Methodology for designing 'intelligence' apparently remains elusive. There are several reasons responsible for resolving this difficult problem. The first one lies in our limited understanding of exactly how the human brain works. The second is that we are all too eager to apply well-known

methods, for example, classical design of expert systems that we fail to see other potential solutions. We can probably cite a few more reasons but that would take away from the main purpose of this paper, which is a description of a potential surrogate solution to real human intelligence.

We recognize that computers as we know them today, due to their intrinsic architecture, are limited and can only function as menial computational tools. However, machines possess an unrelenting and untiring ability to process numbers. If we can find a way to map abstract concepts into numbers then perhaps computers could rise a step or two on the intellectual scale and provide us with the sought after capability of becoming these somewhat intelligent assistants.

The strength of the proposed design is manifested by two important concepts. The first concept lies in grounding the decision-making process to the quantitative data extracted from the message traffic coupled with a physical model of the battlespace at a lower level. The second concept lies in a goal-oriented search for a solution where the commander's intent, mission, task or threats determines the goal. The uniqueness of this approach stems out of a previously tested and original architecture<sup>1</sup>, which allows fast computation in otherwise combinatorially burdened spaces. Fast computation is achieved in part by modeling the computational spaces into several levels of resolution [J. Albus, A. Lacaze, A. Meystel, 1995] coupled with unique but proven algorithms. The proposed architecture can serve the Network Centric and Knowledge Centric paradigms as well as become a general architecture for intelligent agents or for a system of intelligent agents.

## 2.0 Few Important Concepts

### 2.1 Modeling of the World and Context

Computers cannot understand the question "How fast is that object moving?" A human or a computer could respond with "20 km per hour", but a human can also provide a better answer, depending on the context within which the question was asked: "Very fast", "Fast", "Slow" or "Very slow". If we think that we can accomplish that with a "***If Sensor (argument list) Then Effector (argument list)***" statement, then we are missing the point, since computers do not have the faculties to understand the context in which the question is asked. To make the computer answer a question in the proper context, the computer must be aware of the environment in question. We can address the aspect of awareness within the computer by modeling the environment in an entity relational network [Dawidowicz E, 2000], where the objects, which constitute the environment, relate amongst each other. The methodology for modeling this environment is beyond the scope of this paper, however it would suffice to say that the information required to provide required grounding resides in doctrine manuals, textbooks of classical physics and data describing the areas of interest.

---

<sup>1</sup> The architecture proposed here is employed in the Automated Ground Vehicles (AGV) currently under development for Future Combat Systems program

## 2.2 Decision Making or Behavior Generation

Once the world or environment is modeled, the basis for decision-making or behavior generation is found. Changes in the world model are detected as the world model at  $t-1$  is compared to the world at time  $t$ . These changes stimulate an entity relational network, which in turn produce measurable changes in the relationship of existing objects. Before the decision-making process can begin to produce 'decisions', one very important ingredient is required. This ingredient is called the goal. A goal (or set of goals) together with the ability to detect changes within the world model allow for the decision-making process to take place.

## 2.3 Sensors and Sensor Processing

But how does our computational framework realize that the world has changed? It needs sensors. The information provided by sensors stimulates the internal world model. At this point it is important to call the world model a knowledge representation repository. It seems natural to call the world model a knowledge representation repository since our knowledge about the world around us is being represented as the model of "our" world. Certain distinct sensory stimulation could mean little unless we have experienced them before, but before any meaning can be attached to these stimuli, they have to be converted to information, which our own knowledge representation can understand. The signals produced by the outside world have to be detected by the sensors, and then in turn must be processed intrinsically to our knowledge representation. Sensor processing performs the informational mapping between the sensors and our knowledge representation.

## 2.4 Contemplation or Imagination Loop

A Contemplation or Imagination Loop is a process within the Intelligent Node framework that facilitates intelligent behavior. Sensor processing supplies information to the

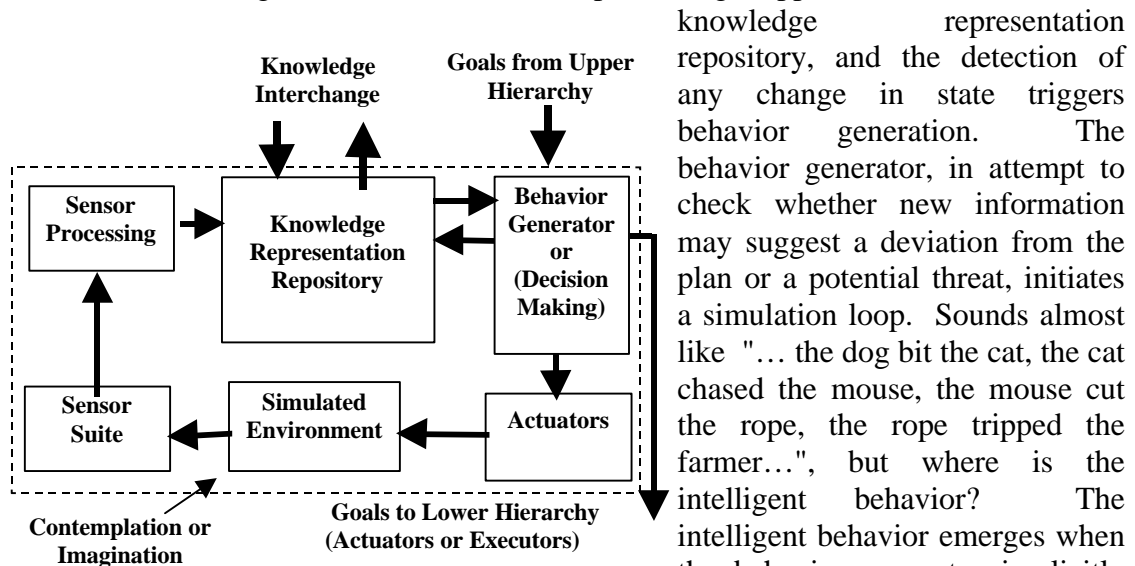

Figure 1. The Elementary Loop of Functioning (ELF)

knowledge representation repository, and the detection of any change in state triggers behavior generation. The behavior generator, in attempt to check whether new information may suggest a deviation from the plan or a potential threat, initiates a simulation loop. Sounds almost like "... the dog bit the cat, the cat chased the mouse, the mouse cut the rope, the rope tripped the farmer...", but where is the intelligent behavior? The intelligent behavior emerges when the behavior generator implicitly raises several questions and attempts to simulate a number of solutions. This thinking loop is the

Elementary Loop of Functioning (ELF) shown in Figure 1. A goal (or sets of goals) together with the ability to detect changes within the world model allow for the actual decision making.

## 2.5 Goals

The mission, mission thread, concept of operation or unit tasks can be decomposed into sets of goals. Through the development of a course of action statement and sketch, the mission statement “Co A will arrive at Assembly Area Tiger at 0601402 Aug 2002”, can be decomposed into a set of goals:

- **Goal 1:** Perform route reconnaissance and planning (By what route will Co A travel to get to AA Tiger)
- **Goal 2:** Determine the potential threats and risks. (Where could they expect to be ambushed or attacked)
- **Goal 3:** Determine the march order and formation based on goals 1 and 2. (What is the march order and formation of Co A.)
- **Goal 4:** Determine the resources required to execute the task. (Do they have the required resources to accomplish the mission? If not, can the missing resources be acquired? If the resources are not available, \ what are the alternatives? Use the alternatives to redefine or refine the applicable results derived from the contemplation loop or modify the earlier defined goals.)

## 2.6 Symbol Grounding and Closure

Symbol grounding is important in modeling ELF's. Symbols allow for the necessary communication to take place between the elements of the ELF internal and external to the loop. The symbol grounding assures that the messages within the Intelligent Node framework are properly interpreted semantically. Therefore, during the multilevel modeling each stage of ELF's must satisfy the symbol grounding at every adjacent loop.

Closure is the foremost property of Intelligent Nodes and should be enabled at all levels of its Architectures (in all cases: human-teams, human-computer interaction, and fully automated unmanned systems). The Elementary Loop of Functioning of an Intelligent Node can be defined at each level of the system under consideration and should be consistently closed in each communication link between the subsystems of IN as described in [J. Albus, A. Meystel, 2001] and [E. Messina, A. Meystel, 2000].

Unlike the classical “feedback loop”, the loop of Intelligent Nodes is not focused upon registering and compensating for the deviation from the goal: it is focused on the goal. Thus, the concept of IN allows for the most pragmatic and adequate representation of the system. As soon as we can explain for a particular scene and/or for a particular situation at a particular level of resolution: who are the ACTORS, what ACTIONS do they develop, and upon which OBJECTS OF ACTION their actions are applied – the Elementary Loop of Functioning has been defined, and thus Intelligent Node has been determined. The subsystems of the loop shown in Figure 2 determine basic properties of the system.

SENSORS (S) are characterized by their ultimate resolution and their scope of the information acquisition per unit of time. In SENSORY PROCESSING (SP), the primary

clustering is performed (together with organization and bringing all available data to the total correspondence), and the resolution of clustered entities is evaluated. Knowledge Representation Repository, KRR (often called World Model) unifies the recently arrived and the earlier stored information messages within a single unified model of representation that determines values of resolution for its subsets. Mapping the couples [goal, world model] into the sets of output commands is performed by BEHAVIOR GENERATION (BG) for the multiplicity of available ACTUATORS (A), actually maps the resolutions of the KRR into the resolutions of the output trajectory of functioning.

Closure of all these units in a single loop (...  $\rightarrow W \rightarrow S \rightarrow SP \rightarrow WM \rightarrow BG \rightarrow A \rightarrow W \rightarrow \dots$ ) is determined by the design of the system and the learning process of defining languages of the IN subsystems.

- The First Fundamental Property of Intelligent Systems Architectures (the property of existence of intelligence), can be visualized in forming the loop of closure.
- Closure is satisfied and the consistency of Intelligent Nodes holds when the unity of language (vocabulary and grammar) holds for each communication link between every pair of Intelligent Node subsystems.
- No matter what the nature of the intelligent system, no matter what the object-oriented domain under consideration, the structure of closure is always the same.

### 3.0 Military Planning Process

The Intelligent Node architecture has many applications outside the military domain, but since our work is focused on the warfighter, we therefore limit our efforts to the continuous military planning process. Military planning is a continuous process and our proposed architecture compliments this process well. The architecture of ELF is designed for continuous planning triggered by incoming information.

A command, mission or orders received from a higher echelon with a clearly stated commander's intent, initiates the military decision making process (MDMP), which is a planning-execution process (Figure 2). This process can be generalized as a sequence of steps:

A higher Operational order initiates a goal-oriented collection of information via communications, generation of decisions, and contemplation of their execution.

Planning is defined as programming of the system's functioning based on the received order and the available information. As a result of planning,

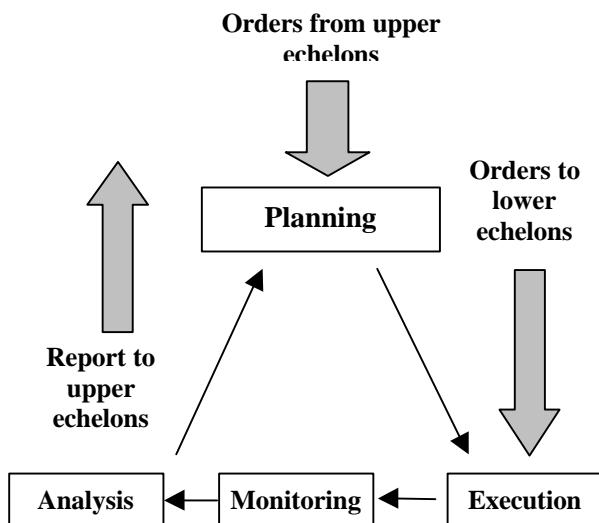

Figure 2. Military planning process

several courses of action (COA) are developed leading to several alternative plans. A final plan is defined as a collection of schedules for independent and/or properly distributed and synchronized processes of functioning subsystems that keep the cost functions within set boundaries. These processes are defined and distributed as sets of orders and verbal instructions to the lower echelons of the organization.

1. Execution starts as soon as the plan is put into action.
2. The execution is continuously monitored.
3. The plan execution is monitored via the continuous interpretation of information contained in messages received from higher and lower echelons.
4. If analysis of this information suggests that a deviation from the original plan is taking place, and this deviation may inflict undesirable consequences, the commander and the unit-planning cell will plan for continued action.

The commander and the members of the unit planning cells are part of our Intelligent Nodes. They aid in the processes of the Decision Making or Behavior Generation element of the ELF.

#### 4.0 Intelligent Nodes

The ELF architecture is well suited for developing the architecture of the Intelligent Nodes, however this requires explanation and will become evident when we discuss how

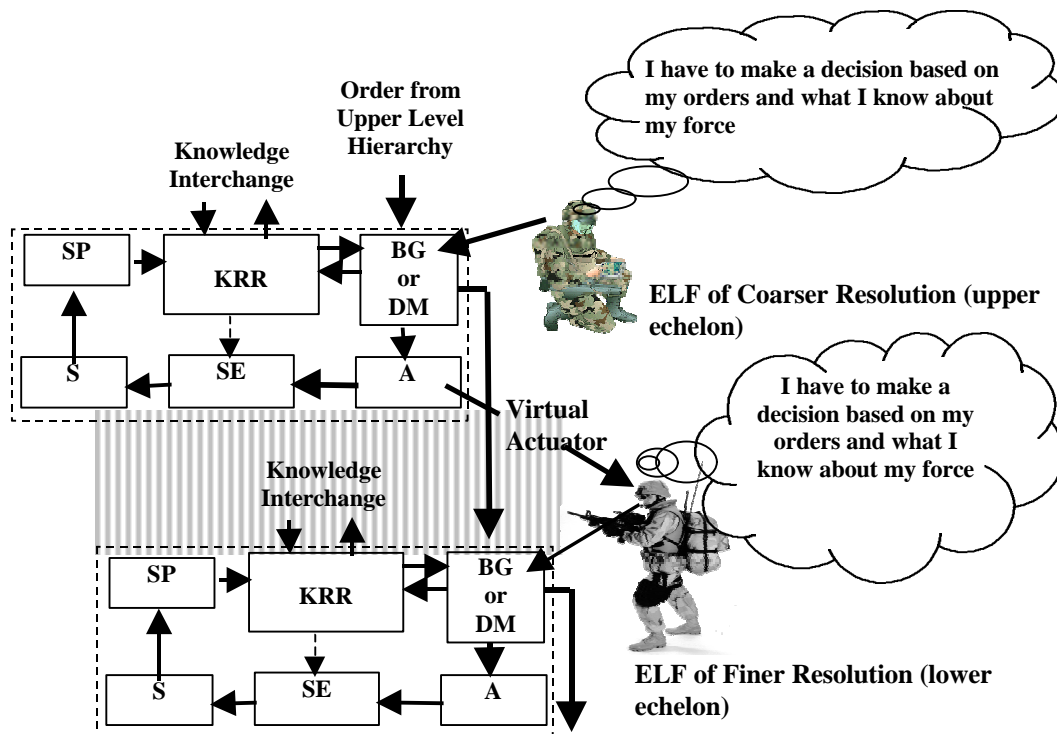

Figure 3. Commander and Subordinate Commander Intelligent Nodes

the ELF fits into the Intelligent Node framework. A planning cell is an instance of the Intelligent Node, where warfighters and automation work together towards a common

goal. The scope of this paper is limited to a discussion of the automation part of the Intelligent Node.

#### 4.1 Levels of Resolution and Collaboration

For the purposes of our discussion, the KRR within the Intelligent Node will be limited to only three<sup>2</sup> levels of resolution:

- The level above to understand the commanders intent
- Own level (echelon level of a particular node) to generate individual goals and perform planning and monitor execution.
- The level below to understand how subordinate units responds to the higher commander’s intent.

This type of modeling allows us to simplify computation dramatically, allow for inter-echelon understanding and support a critical element called collaboration. Also, this modeling is doctrinally valid since the lower the echelon, the higher the granularity

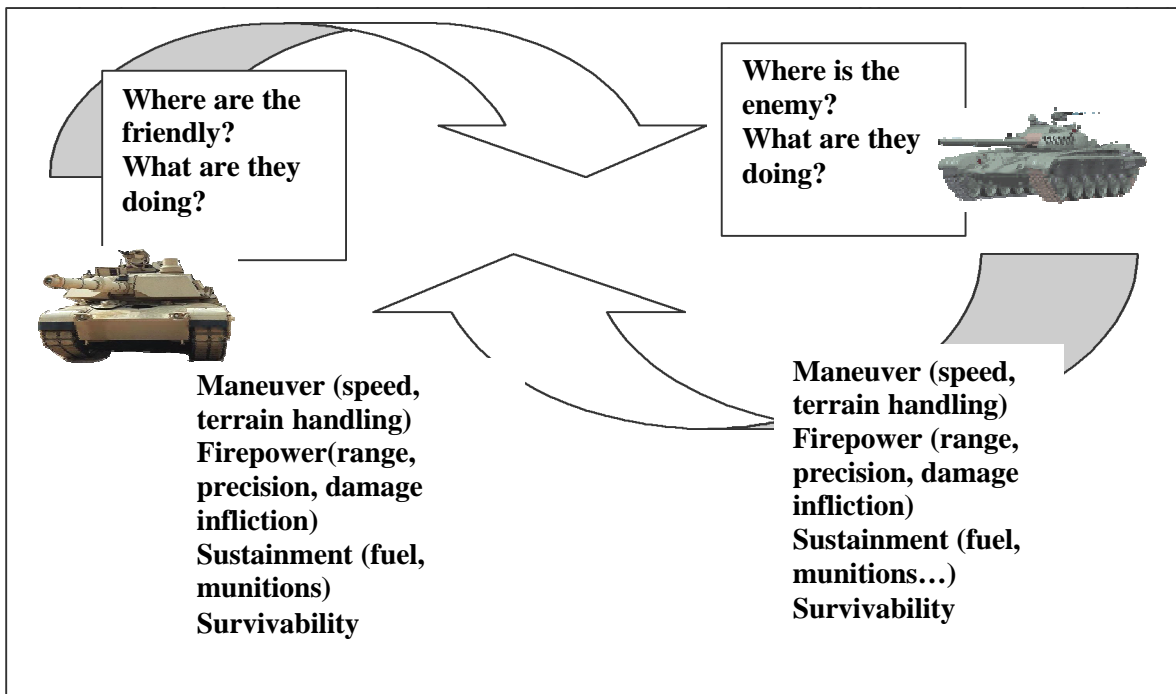

Figure 4. Elements of Common Operational Picture (COP)

The example used here in terms of terrain elevation points can be extended to other objects and using their own particular attributes to form relationships, we can structure entity-relational networks, where the aspect of granularity becomes extremely important. The entity relational networks by themselves can thus become indispensable computational tools.

Collaboration among Intelligent Nodes is yet another powerful concept. As we reduce the computational complexity by using multi-resolutional modeling, we can reduce it even further by using distribution of labor among our Intelligent Nodes for the planning

<sup>2</sup> According to the doctrine, modeling of four levels of resolution is required.

process. For example, since all three companies are at the same level of resolution and intend to take the same route, it appears that only one company needs to do the route planning while the other company may consider detecting areas of potential ambush while the third company is able to look for available assets. In the process of continuous collaboration the KRR of every Intelligent Node gets updated therefore maintaining information/knowledge sharing and continuously updating the Common Operating Picture (COP) (Figure 4).

#### ***4.2 Putting the Concepts Together***

The ELF architecture allows reasoning in terms of physical object representations, their relationships to each other and continuously computing the cost functions associated with changes within the area of interest and updating the World Model. Multi-modal data, or data from different sources, is processed for task or situational relevance. ELF is incorporated into Intelligent Nodes as the main building block allowing the Intelligent Nodes to maintain a continuous awareness of the relevant environment and continuously analyzing pertinent or emerging courses of action. This allows the contents of messages; sensor data or user requests to be mapped into the world model to quickly respond to deviations in planned execution, emergencies or threats. Intelligent Nodes are capable of the following:

- Intelligent assistants
- Robotics
- Collaborative agents
- Tool for Mission Planning, Course of Action Analysis, Situational analysis, Natural Language Interface
- Process control and optimization agents
- Biometric information collection for security profile, and intrusion detection.

#### ***5.0 Conclusion***

Coalition forces face problems in communication and information distribution constrained by security, information packaging, information dissemination, operational doctrine and finally, language. The proposed architecture allows for addressing these problems by providing automated information processing at every command node. The imbedded symbol grounding provides the necessary basis for machine cognition, and permits natural language communication. The current Future Combat Systems (FCS) program, together with the ongoing rapid evolution of the Army into a futuristic, multifunctional Objective Force in collaboration with Coalition partners, requires implementation of new ideas and concepts into current and developing combat systems in which machines will synergistically work together with humans to achieve quick and decisive victories with minimum loss of life. The concept of Intelligent Nodes presented in this paper will provide that critical capability and environment, where machines will be able not only to communicate with humans in a natural language [S. A. Carey, et al 2001], but will also understand the interaction of other users and the message traffic



within their environment and in the proper context, thereby reducing manpower and produce the on demand or requested right information at the right time.

#### REFERENCES

1. [J.S. Albus, A. M. Meystel, 2001] James S. Albus, Alexander M. Meystel, *Engineering of mind: an introduction to the science of intelligent systems*, John Wiley & Sons, Inc, New York, 2001.
2. [S. A. Carey, et al 2001] S. A. Carey, M. S. Kleiner, M.R. Hieb, R. Brown, "Standardizing Battle Management Language - A Vital Move Towards the Army Transformation, 2001 Fall Simulation Interoperability Workshop, <http://www.sisostds.org/siw/01fall/readlist.htm>
3. [E. Dawidowicz, 2001] Edward Dawidowicz, "Performance Evaluation of NCW Oriented Intelligent Systems," in Proceedings of The Second International Workshop on Performance and Intelligence of Intelligent Systems, PERMIS'2001 at IEEE ISIC, Mexico City, Mexico, 2001, Published by NIST, Gaithersburg, MD 2002
4. [Dawidowicz E, 2000], Dawidowicz E, "Towards Smart Intelligent Agents in the Command and Control Environment", Proceedings of 2000 Command and Control Research and Technology Symposium, Naval Postgraduate School, Monterey, CA, June 26-28, 2000
5. [E. Messina, A. Meystel, 2000] E. Messina, A. Meystel, "The Challenge of Intelligent Systems," Proceedings of the 2000 IEEE International Symposium on Intelligent Control, Eds. P. Groumpos, N. Koussoulas, M. Polycarpou, July 17-19, Patras, Greece, 2000
6. [A. M. Meystel, J.S. Albus, 2001] Meystel, J. Albus, "*Intelligent Systems: Architectures, Design, Control*", Wiley, NY, 2001
7. [S. Harnad, 1990], S. Harnad (1990) The Symbol Grounding Problem. *Physica D* 42: 335-346, <http://www.ecs.soton.ac.uk/~harnad/Papers/Harnad/harnad90.sgproblem.html>
8. [Morrisons, et al, 1982] *Powers of Ten*, by Morrisons and the Office of Charles and Ray Eaems, Scientific American Library, NY, 1982
9. [H. Pattee, 1973] Ed. by Howard H. Patee, *Hierarchy Theory: The Challenge of Complex Systems*, Braziller, New York, 1973
10. [E. Dawidowicz and A. Meystel in print] E. Dawidowicz, A. Meystel, "Modeling of Communication Flows in Systems with Intelligent Nodes", in Proceeding of the Workshop on Theoretical Fundamentals of Intelligent Systems, held in March 2002 as a part of JCIS, in Durham, NC., (in print).
11. [J. Albus, A. Meystel J, 2001]. Albus, A. Meystel, *Engineering of Mind: An Introduction to the Science of Intelligent Systems*, Wiley, NY 2001
12. [M. Minsky , 1983] M. Minsky, *The Society of Mind*, Simon and Schuster, New York, 1985
13. [A. Meystel , 1996] A. Meystel, "Intelligent Systems: A Semiotic Perspective", *International Journal of Intelligent Control and Systems*", Vol.1, No. 1, 1996, pp. 31-58
14. [A. Meystel 1997] A. Meystel, "Learning Algorithms Generating Multigranular Hierarchies", in *Mathematical Hierarchies and Biology*, Eds.: B. Mirkin, F. R. McMorris, F. S. Roberts, A. Rzhetsky, DIMACS Series in Discrete Mathematics, Vol. 37, American Mathematical Society, 1997, pp. 357-384
15. [S. Kaufmann , 1996] S. Kaufmann, "The World of Autonomous Agents and the Worlds They Mutually Create", Lectures, 1996, (<http://www.santafe.edu/sfi/People/kauffman/Investigations.html>)
16. [J. Albus, A. Lacaze , A. Meystel ,1995] J. Albus, A. Lacaze, A. Meystel, "Autonomous Learning via Nested Clustering", Proc. of the 34th IEEE Conference on Decision and Control, Vol.3, New Orleans LA, 1995, pp. 3034-3039
17. [J. Albus, A. Lacaze , A. Meystel , 1995]J. Albus, A. Lacaze, A. Meystel, "Theory and Experimental Analysis of Cognitive Processes in Early Learning", Proc. of the 1995 International Conference on Systems, Man and Cybernetics "Intelligent Systems for the 21st Century", Vancouver, BC Canada, 1995, pp. 4404-4409
18. [A. Meystel , 2001] A. Meystel, "Simulation for Meaning Generation: Multiscale Coalition of Autonomous Agents," In Eds. H. Sarjoughian, F. Cellier, *Discrete Event Modeling and Simulation Technologies*, Springer, NY, 2001, pp. 263-296
19. [J. Albus, A. Lacaze, A. Meystel, 1995] J. Albus, A. Lacaze, A. Meystel, "Autonomous Learning via Nested Clustering", Proc. of the 34th IEEE Conference on Decision and Control, Vol.3, New Orleans LA, 1995, pp. 3034-3039
20. [J. Albus, A. Lacaze, A. Meystel, 1995] J. Albus, A. Lacaze, A. Meystel, "Multiresolutional Intelligent Controller with Unsupervised Learning", Proc. of the 4th IEEE Conference on Control Applications, Albany, NY, 1995, pp. 543-548

21. [J. Albus, A. Lacaze, A. Meystel, 1995] J. Albus, A. Lacaze, A. Meystel, "Algorithm of Nested Clustering for Unsupervised Learning", Proc. of the 10th IEEE Int'l Symposium on Intelligent Control, Monterey, CA, 1995